

Pinnacle
Since 1976



Pinnacle Machine Tool Co., Ltd.

No. 149, Sec. 1, Goufeng Rd., Shengang Dist.,
Taichung City 42949, Taiwan
TEL:886-4-25252995
FAX:886-4-25252991
E-mail:info@pinnacle-mc.com
http://www.pinnacle-mc.com



2017.03.1000-6

High-Tech Expertise in
5-axis machining
Strategies for success in cutting edge technology





Pinnacle
"exceeds your expectation"

WIDE PRODUCT RANGE

Pinnacle Machine Tool Co., Ltd. was founded in 1976. With excellent experience in **Technology, Quality & Service**. We are specialized in manufacturing all kinds of machining centers such as 5-axis, double column, vertical, and horizontal. Furthermore, we have a wide range of CNC lathes as well. The complete product lines with outstanding quality satisfy the needs of our valuable customers worldwide.

STRONG TECHNICAL SUPPORT & AFTER SERVICE

R&D is teamed up by experienced engineers with decades of expertise in machine tool industry. By means of applying up-to-date technologies such as CAD/CAM/CAE software and Finite Element Analysis, our machines are robustly constructed, assuring optimum rigidity and stability. Our reliable partnerships with dealers keep us connected closely with the latest technologies and market trends, hence ensuring Pinnacle product developments are upgraded constantly.

Well-trained service engineers are familiar with each step of assembly to ensure our quality service works and keep all machines running in the best status. Training courses to service engineers are held periodically to keep the team refreshed with the latest technology and skills.

Pinnacle's reputation is built on quality, it relies on an excellent quality control system and systematic management. The in-coming parts are inspected under the highest standard by using precision equipment during production, assembly and final test run processes.

The sales and service departments provide customers pre-sale and after-sale services. Prompt reaction is just our basic attitude to all customers only, accurate and effective technical solutions are provided within the shortest time.





Optimum rigidity by separating **rotary axis** and **tiling axis**.

High-Tech Expertise in 5-axis Machining

5-AXIS MACHINING CENTER

BX series machines by Pinnacle offer the latest and most precise 5-axis technology in the market. Simplify setup and production of complex and multi-sided parts without sacrificing precision and accuracy and saving time. Optimized 5-axis concepts meet every requirement and prevail in all industries worldwide. BX series by Pinnacle are High rigidity structure to provide the widest working range. High quality Meehanite casting iron, tempered for stress relief and over HB190 hardness to ensure deformation-free performance year after year.



BX300A / BX500A / BX700A

BX300A / BX500A and BX700A, a 5-axis control vertical machining center with a swivel head and rotary table design. Rotary table is removable and machine could work as a 4 axes machine.

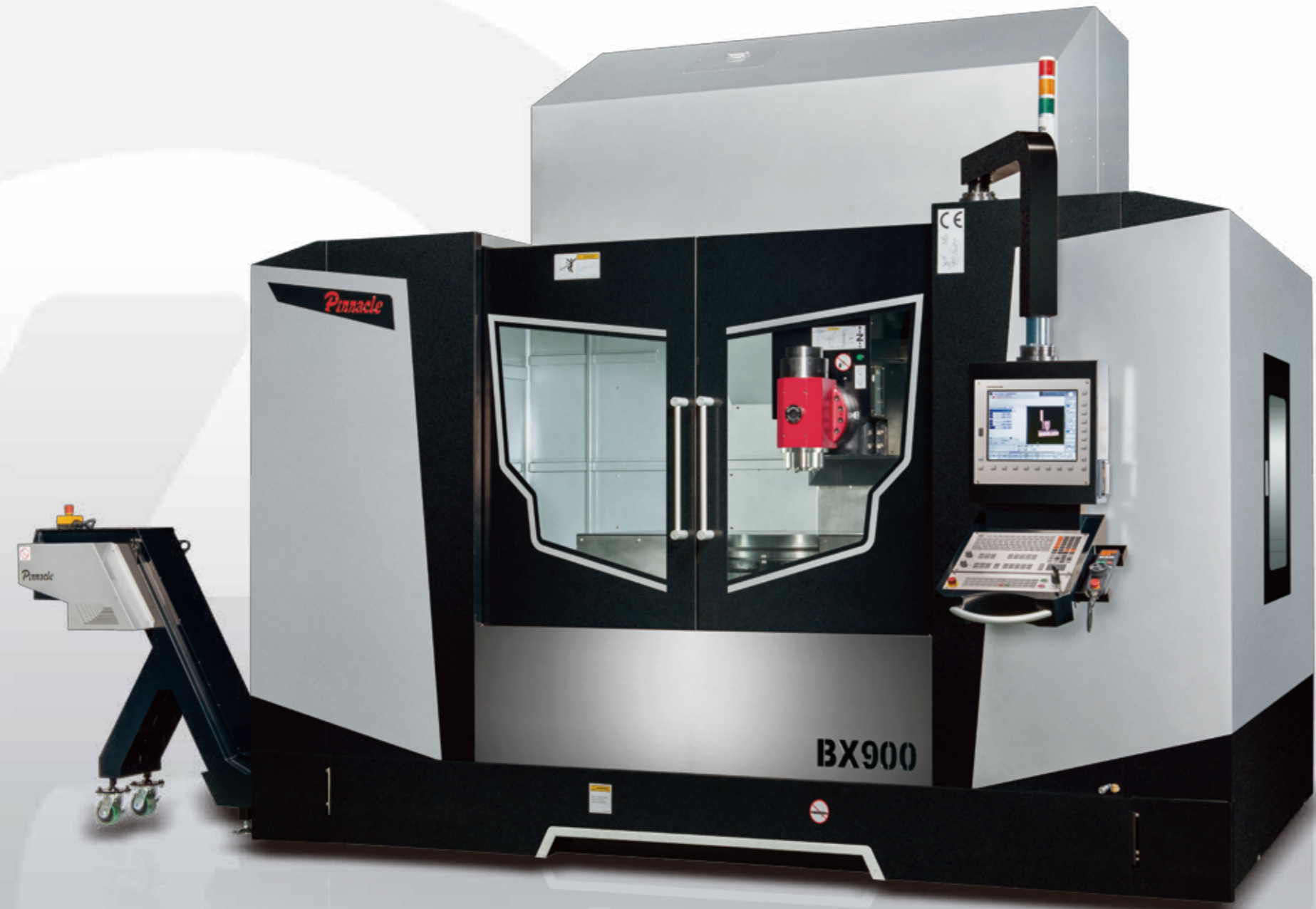

BX900 / BX700 / BX500

BX900 / BX700 / BX500 a high precision, 5-axis control vertical machining center that employs a swivel head with DD Motor on the rotary table to achieve the highest productivity in 5 axis machining.

Unique Patented Design

Patent No. M386957 (Taiwan)

ZL200920219035.9 (China)



Features of Integrated C axis with T-Slot Table:

1. Rotary table surface and standard T-slot table are on the same plane, it accommodates larger and heavier work pieces.
2. Direct drive C axis.
3. 0.001° minimum position accuracy supported by high rigidity bearing and hydraulic braking system.
4. Permanent magnetic motor provides high torque output and high power to meet different cutting application demands.

C-axis for BX900T / BX700T has max speed up to 800rpm or 1200rpm for turning function.



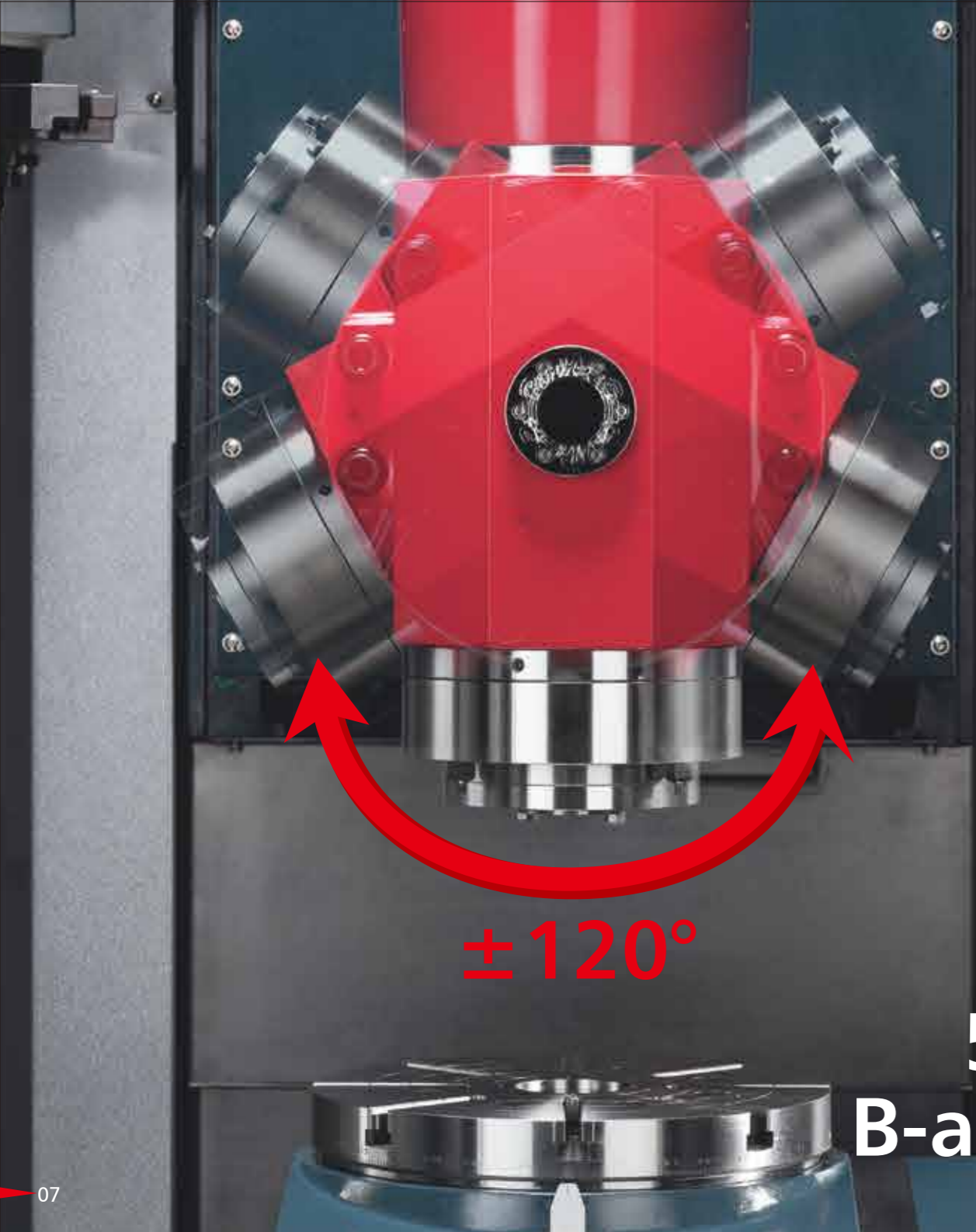

Hi-Speed, Hi-Power, Hi-Torque, Built-in Spindle 15000 rpm, swivels $\pm 120^\circ$

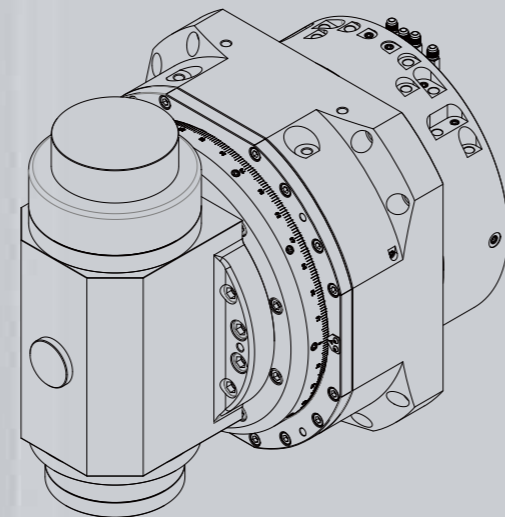

Unique B-axis Design

- The transmission mechanism of B axis for model BX500DD / BX700DD / BX900DD is innovated from dual worm wheel/shaft to direct drive. In addition to the smooth and powerful torque, the direct driving system features higher rotation speed, high servo response, zero backlash, and outstanding dynamic accuracy for the optimum workpiece surface finish. The external cooling system efficiently minimizes the structural thermo deformation and accuracy deflection, moreover, the output torque is upheld since the temperature is constantly kept in low and stable level.
- The rear end of B axis shaft is fitted with an angular position coder (RCN729) to boost positioning accuracy of B axis. The application of direct drive motor in B and C axis increases the overall accuracy as well as machining efficiency of the machine.

5-AXIS Machining Center B-axis swivel Milling Head



Outstanding Craftsmanship

Pneumatic Balance System

The Z-axis is pneumatic counter-balanced via high response pneumatic cylinders. Plus an air reservoir tank to boost the balancing performance, ensuring fast and stable Z-axis movement, giving high surface finish (Not for BX900 / BX900T).

Cooling System to Spindle

The spindle oil cooler permits the spindle to keep a constant temperature running and ensures long service life. It also provides high efficiency machining and high accuracy.

Hollow Ball Screw with Cooling System

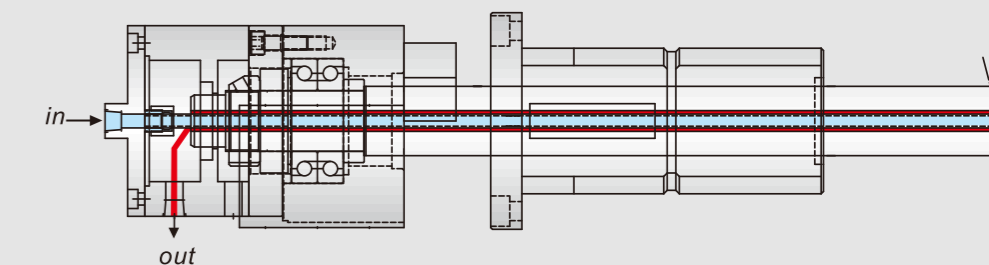

Oil cooling through ball screws on X, Y, Z axis minimizes thermal deformation and backlash, while ensuring smooth motion during rapid traverse.

Spindle Torque Output Diagram

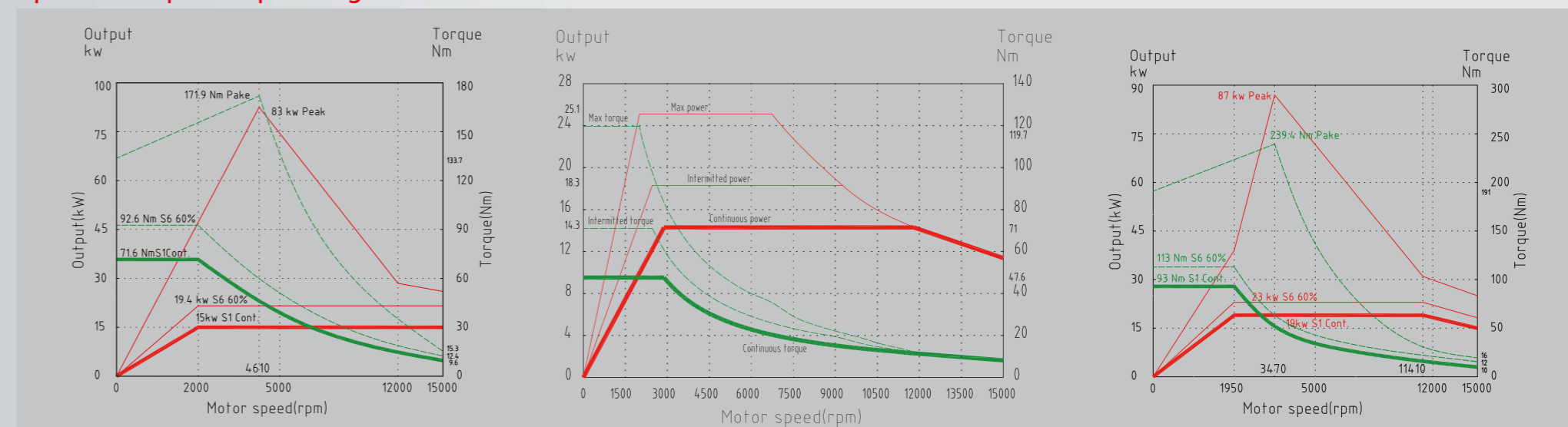

Pinnacle BX is the best cost-effective manufacturing investment of 5-axis simultaneously controlled machining centers, it brings positive and instant results by improving machining accuracy and reducing cutting time.



BX700 / BX500 is high speed, high accuracy with HEIDENHAIN iTNC530 5-axis simultaneously controlled machining center. Equips 15000rpm built-in spindle, B-axis swivel head $\pm 120^\circ$, and C-axis $\varnothing 630\text{mm}$ rotary table (Built-in DD C-axis) to optimize machining space and allows complex workpieces to be finished in just one setup and reduces cycle time.



WORK RANGE

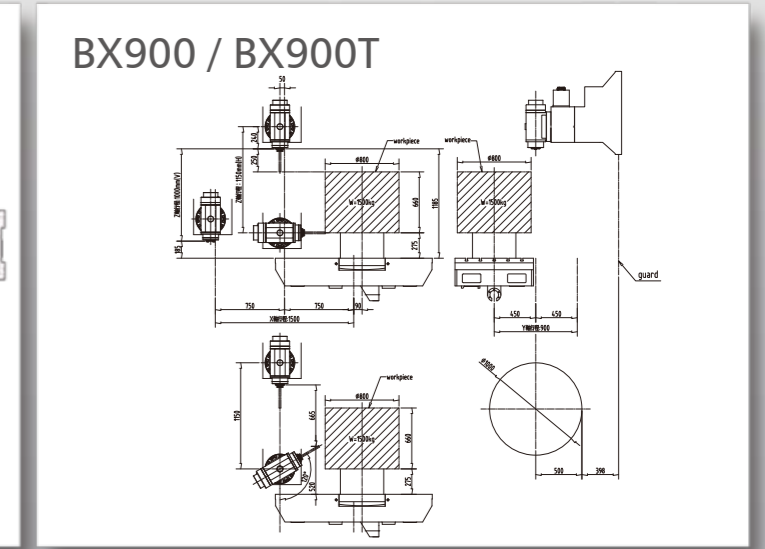
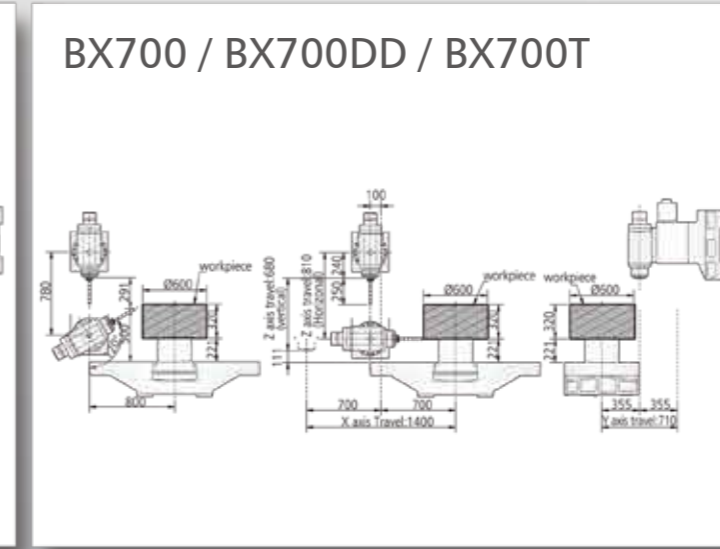
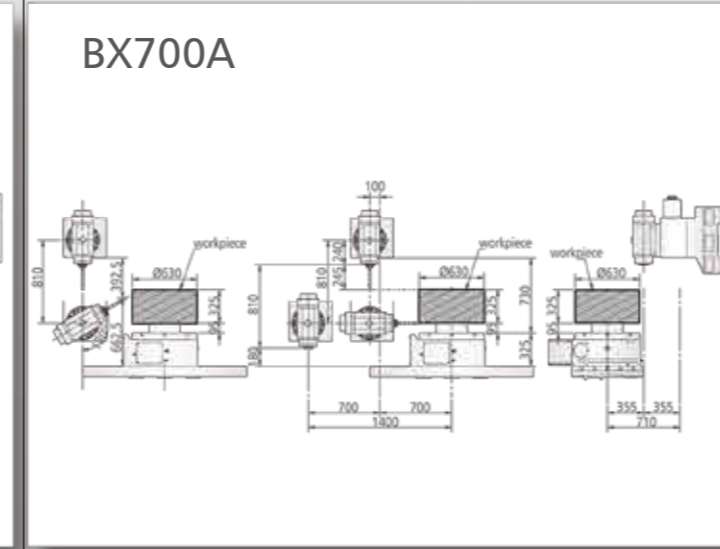
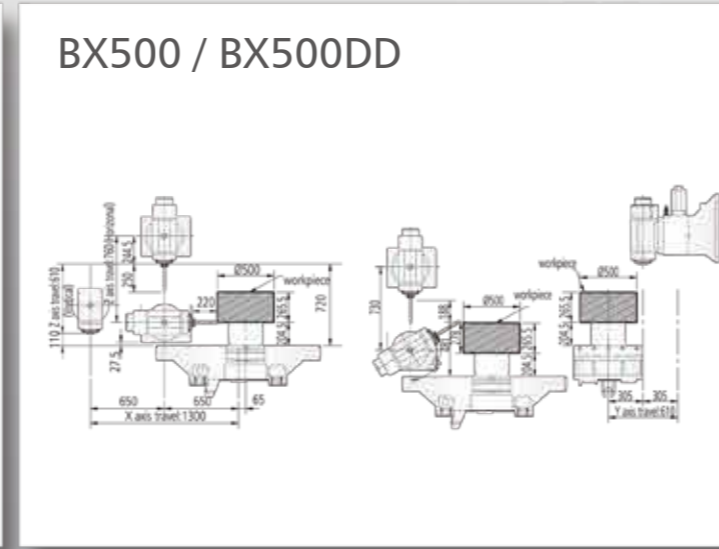
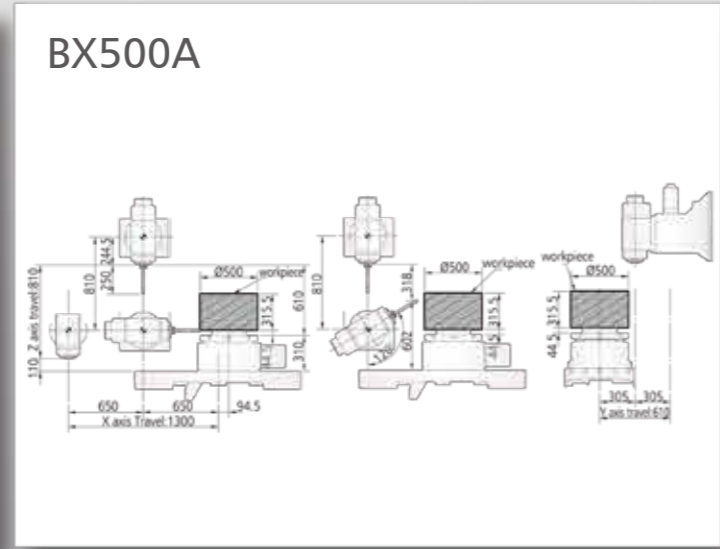
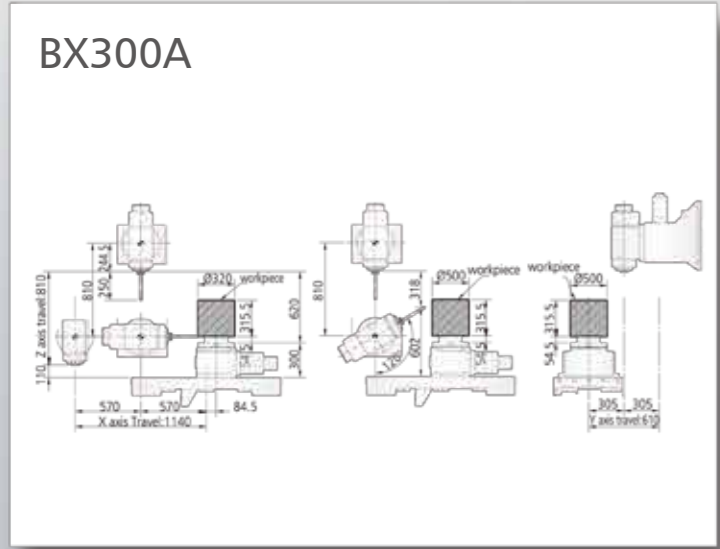



CNC CONTROLLER SYSTEM

BX series is high speed, high accuracy with HEIDENHAIN iTNC530 5-axis simultaneously controlled machining center. Standard with 15000rpm built-in spindle.

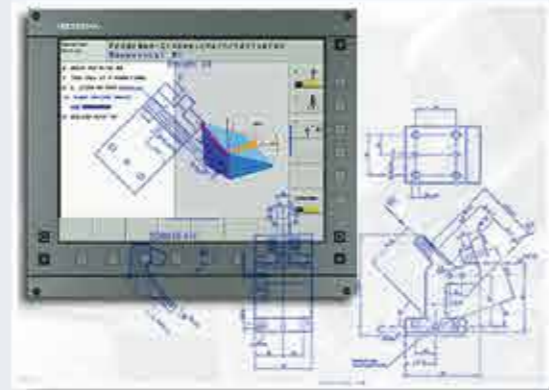

PLANE Function
The PLANE feature makes it easy to define a tilted working plane.



DCM (Dynamic Collision Monitoring)
DCM enables you to check for collisions in the test run mode before actually machining a part. To avoiding machine down times. Simulation for a safety process.

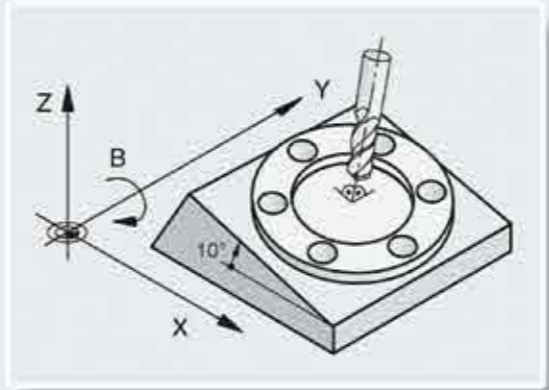

Tilting the Working Plane
With Cycle 19 with swivel heads or tilting tables, you program the operation as usual in the working plane, for example in X/Y. The machine runs the program in a plane that has been tilted by one or more rotary axes with respect to the main plane.

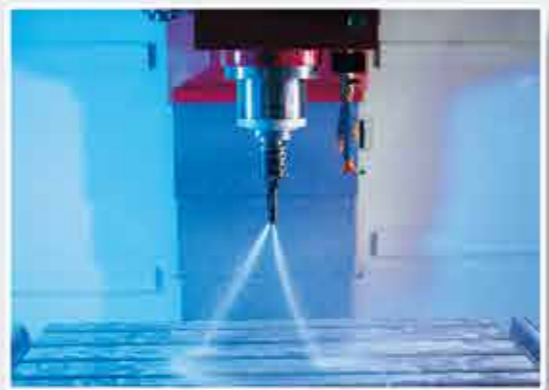

Coolant Through Spindle (Option)
20 Bar high pressure pump and sub tank assure CTS system offers the highest efficiency of chip disposal.

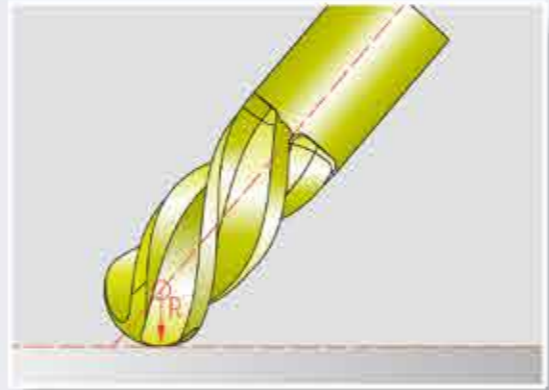

TCPM function (Tool Center Point Management)
In five-axis operations, TCPM function to move the tool reliably on the contour and ensure that the work surface is not damaged. Maintain the position of the tool tip when positioning with tilted axes. With the aid of the TCPM function, the iTNC 530 automatically corrects the tool path for the machine geometry and the tool length as well as compensates the tool radius in three dimensions.



Chip Conveyor (Option)
Hinge type or scraper type chip conveyor in front side of machine (able head to left or right) removes chips from machine.



Chip Flushing System
Chip flushing system is equipped to remove cutting chips inside of enclosure, which prevents chip accumulation and any possible damage to the linear guideways and ball screws.



Kinematic Opt. (Option)
Kinematics Opt is an important component to help you meet these high requirements: With a HEIDENHAIN touch probe inserted, a 3-D touch probe cycle measures your machine's rotary axes fully automatically. The results of measurement are the same, regardless of whether the axis is a rotary table, a tilting table or a swivel head.

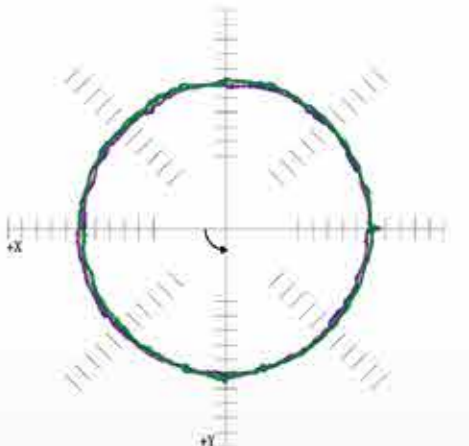

BALL BAR DIAGNOSTICS

All Aspect Quality System

Quality comes not from inspection but from every Pinnacle staffs' mentality. The state-of-the-art inspection equipments only help us to prove our attitude and accuracy results.

Quality is not a job, it is our attitude.



ISO certification



CE certification

FLOOR SPACE:

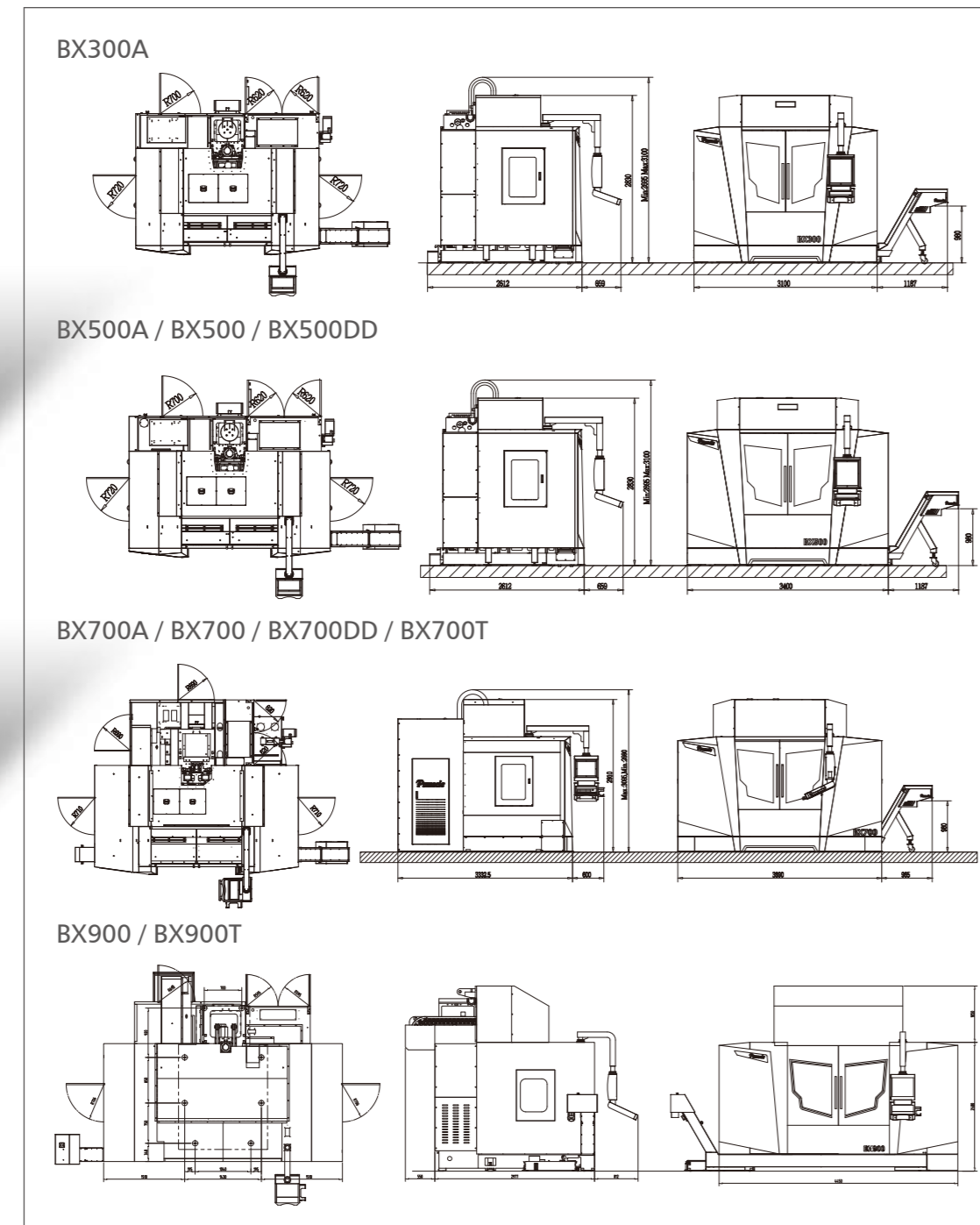

SPECIFICATIONS:

MODEL	BX300A	BX500A	BX500	BX500DD	BX700A	BX700	BX700DD	BX700T	BX900	BX900T
TABLE										
Table Size (mm)	1300x610	1450x610	1450x610	1450x610	1600x700	1600x700	1600x700	1600x700	1700x850	
Travel Ranges X / Y mm	1140/610	1300/610	1300/610	1300/610	1400/710	1400/710	1400/710	1400/710	1500/900	
Travel Ranges Z mm	810	810	V610 / H760	V 610 / H760	810	V 680 / H 810	V 680 / H 810	V 680 / H 810	Vertical 1000, Horizontal 1100	
Max. Table Load (kg)	850	850	850	850	1000	1000	1000	1000	1200	
Spindle Nose to Table Surface (Vertical) (mm)	110~920	110~920	110~720	130~740	180~990	110~790	110~790	100~780	115~1115	
Spindle Center to Table Surface (Horizontal) (mm)	355~1165	355~1165	205~965	205~965	420~1230	220~1030	220~1030	220~1030	255~1355	
T-slot (W x D x N mm)	18x125x5	18x125x5	18x125x5	18x125x5	18x125x5	18x125x5	18x125x5	18x125x5	18x150x5	
BUILT-IN SPINDLE										
Spindle Taper	DIN40	DIN40	DIN40	DIN40	DIN40	DIN40	DIN40	HSK63T	DIN40	HSK63T
Bearing Inner Diameter (mm)	Ø70	Ø70	Ø70	Ø70	Ø70	Ø70	Ø70	Ø70	Ø70	Ø70
Spindle Center to Column (mm)	675	675	675	675	760	760	760	800	950	950
Spindle Speed (rpm)	15000	15000	15000	15000	15000	15000	15000	15000	15000	15000
Draw Bar Force (Kgf)	800±100	800 ±100	800 ±100	900 ±100	900±100	900 ±100	900±100	1800±100	900±100	1800±100
Main Motor (con/56 60% kW)	15/18	15/18	15/18	15/19.4	15/19.4	15/19.4	15/19.4	19/23	15/19.4	19/23
Motor Torque (con/max Nm)	48/120	48/120	48/120	71.6/172	71.6/172	71.6/172	71.6/172	93/113(S6)	71.6/172	93/113(S6)
SWIVEL HEAD										
Driver Type	WORM GEAR	WORM GEAR	WORM GEAR	Direct drive	WORM GEAR	WORM GEAR	Direct drive	Direct drive	Worm gear	Direct drive
Reduction Ratio	1:72	1:72	1:72	-	1:120	1:120	-	-	1 : 120	-
Tilting Range (deg)	±120°	±120°	±120°	±120°	±120°	±120°	±120°	±120°	±120°	±120°
Max. Speed (rpm)	25	25	25	50	16.6	16.6	50	50	16.6	50
Min. Unit(deg)	0.001	0.001	0.001	0.001	0.001	0.001	0.001	0.001	0.001	0.001
Clamp Torque (Nm)	1157	1157	1157	2950	1765	1765	2950	2950	1765	2950
Working Torque (Nm)	764	764	764	689	765	765	689	689	765	686
ROTARY TABLE										
Type	SEPARATED	SEPARATED	EMBEDED	EMBEDED	SEPARATED	EMBEDED	EMBEDED	EMBEDED	EMBEDED	EMBEDED
Driver Type	WORM GEAR	WORM GEAR	Direct drive	Direct drive	WORM GEAR	Direct drive	Direct drive	Direct drive	Direct drive	Direct drive
Table Diameter (mm)	Ø320	Ø500	Ø500	Ø500	Ø630	Ø630	Ø630	Ø640	Ø800	Ø800
Center Bore Diameter (mm)	Ø70	Ø60	Ø50	Ø50	Ø75	Ø50	Ø50	Ø50	Ø50	Ø50
Rotation Speed (rpm)	22.2	11.1	50	50	11.1	50	50	50(M) / 1200(T)	50	50(M) / 800(T)
Min. Unit (deg)	0.001	0.001	0.001	0.001	0.001	0.001	0.001	0.001	0.001	0.001
Max. Table Load(kg)	350	500	500	500	800	1000	1000	800(M) / 500(T)	1200	800(M) / 500(T)
AXIS SERVO MOTORS										
Rapid Feed Rate (XY / Z m/min)	36/36/24	36/36/24	36/36/24	36/36/24	36/36/24	36/36/24	36/36/24	36/36/24	20/20/16	
Cutting Feed Rate (X / Y / Z mm/min)	10000	10000	10000	10000	10000	10000	10000	10000	10000	
X / Y / Z-axis Rated Torque (Nm)	11/11/11	11/11/11	11/11/11	11/11/11	18.1/18.1/18.1	18.1/18.1/18.1	18.1/18.1/18.1	18.1/18.1/18.1	30.6/30.6/30.6	
B-axis Rated Torque (Nm)	11	11	11	11	11	11	689	689	11	
C-axis Rated Torque (Nm)	11	11	315	315	11	533	533	533	533	

• ALL SPECIFICATIONS AND DESIGNS ARE SUBJECT TO CHANGE WITHOUT NOTICE.

MODEL	BX300A	BX500A	BX500	BX500DD	BX700A	BX700	BX700DD	BX700T	BX900	BX900T
TOOL MAGAZINE										
CAM Type	DAUL ARM	DAUL ARM	DAUL ARM	DAUL ARM	DAUL ARM	DAUL ARM	DAUL ARM	DAUL ARM	DAUL ARM	DAUL ARM
Tool Selection (Bi-Direction)	RANDOM	RANDOM	RANDOM	RANDOM	RANDOM	RANDOM	RANDOM	RANDOM	RANDOM	RANDOM
Tool Storage Capacity (PCS)	30 (40, 60)	30 (40, 60)	30 (40, 60)	30 (40, 60)	30 (40, 60)	30 (40, 60)	30 (40, 60)	30 (40, 60)	30(40, 60)	30(40, 60)
Max. Tool Diameter (mm)	Ø75	Ø75	Ø75	Ø75	Ø75	Ø75	Ø75	Ø75	Ø75	Ø75
Max. Tool Length (mm)	250	250	250	250	250	250	250	250	250	250
Max. Tool Weight (Kgs)	8	8	8	8	8	8	8	8	8	8
ACCURACY										
Positioning XYZ linear axis (mm)	0.005	0.005	0.005	0.005	0.005	0.005	0.005	0.005	0.005	0.005
BC rotary (sec)	14" / 14"	14" / 14"	14" / 10"	10" / 10"	14" / 14"	14" / 10"	10" / 10"	10" / 10"	14" / 10"	10" / 10"
Repeatability XYZ linear axis (mm)	0.003	0.003	0.003	0.003	0.003	0.003	0.003	0.003	0.003	0.003
BC rotary (sec)	8" / 8"	8" / 8"	8" / 6"	6" / 6"	8" / 8"	8" / 6"	6" / 6"	6" / 6"	8" / 6"	6" / 6"
MISCELLANEOUS										
Air Requirement (Kg/cm ²)	6	6	6	6	6	6	6	6	6	6
Voltage	380	380	380	380	380	380	380	380	380	380
Power Requirements (KVA)	40	40	40	40	40	40	40	40	50	50
Coolant Tank Capacity (L)	300	300	300	300	450	450	450	450	700	700
Machine Weight (KGs)	6500	6800	7200	7200	11000	12000	12000	12000	15000	15000
Machine Height (mm)	3100	3100	3100	3100	3200	3200	3200	3200	3450	3450
Floor Space (LxW mm)	3100x2230	3400x2230	3400x2230	3400x2230	3890x3180	3890x3180	3890x3180	3890x3180	4450x4340	4450x4340
Packing Size (LxWxH mm)	3150x2300x2550	3450x2300x2550	3450x2300x2550	3450x2300x2550	3230x2300x2560	3230x2300x2560	3230x2300x2560	3230x2300x2560	4300x3260x4030	4300x3260x4030

Standard accessories:

- Air Blast Through Spindle
- Coolant System
- Full Splash Guard
- Automatic Lubrication System
- Working Lamp
- Operation Status Light
- Rigid Tapping
- Air Gun / Water Gun
- MPG Handwheel
- Spindle Oil Cooler
- B-axis Rotary Encoder
- C-axis Rotary Encoder
- Hollow Ball Screws with Cooling System

Optional Accessories:

- Optical Scale on X/Y/Z axes
- CTS 20bar
- Work Piece Measurement System
- Tool Length Measurement System
- Oil Mist Collector
- Transformer
- Stabilizer