

BDMS

PRODUCT CATALOGUE





BDMS / COMPANY PROFILE

BDMS is a leading supplier of new and used CNC equipment backed up by our network of service and application engineers Australia wide. Our focus is to supply innovative and cost effective solutions to our broad customer base.

Our range of new CNC machines are of the highest quality at affordable prices, however, it doesn't stop there, the team at BDMS are on hand to assist you with ongoing training and service support. We work with our customer in finding the correct machine for your needs. We also source quality used machines globally and have a wide variety of stock machines available for immediate use at competitive prices.

BDMS can assist you in selling your surplus machines through our extensive advertising campaigns, our job is to maximise your return in the shortest possible time. Whatever your requirements are, we aim to exceed your expectations.

Stewart Eason
Director

BDMS / CONTENTS

CNC
MACHINERY
SALES
SPECIALISTS.

At BDMS our
goal is to
exceed your
expectations

- / 3. Used Machines
- / 5. Pinnacle Machine Tools
- / 47. Ecoca Machine Tools
- / 57. MyDay Machine Tools
- / 63. Sanco Machine Tools
- / 69. Winho L series
- / 71. SMTCL Machine Tools
- / 75. Vertex Machine Accessories
- / 79. GSA CNC Rotary Tables

QUALITY MACHINES
ALWAYS IN STOCK

VISIT WWW.BDMS.COM.AU
FOR A COMPREHENSIVE
RANGE OF USED
MACHINES



SELL YOUR SURPLUS MACHINES
ON CONSIGNMENT



USED MACHINES

TAKE ADVANTAGE OF OUR DATABASE
OF CUSTOMERS LOOKING FOR
QUALITY MACHINES

ALL USED
MACHINES ARE
COMPREHENSIVELY
CHECKED BY
OUR TEAM OF
TECHNICIANS PRIOR
TO SALE

WE CAN FIND THE
RIGHT MACHINE
FOR YOUR
REQUIREMENTS

ALWAYS BUYING
USED MACHINES
WITH SAME DAY
SETTLEMENT

LIST YOUR MACHINE
ON OUR WEBSITE



Pinnacle Product Range

Pinnacle Machine Tool Co - Our premium range of machines

With fast delivery schedules and very competitive prices, Pinnacle machines are fast becoming a very popular machine in Australia. A strong focus on quality and research & development, have allowed Pinnacle to offer a wide range of products from conventional turret mills to large 5 axis machines. BDMS are proud to be the sole distributor for Pinnacle products and have been associated with the company for over 15 years.

BX700

PNEUMATIC BALANCE SYSTEM

COOLANT THROUGH BALL SCREWS

CNC CONTROLLER SYSTEM

PLANE FUNCTION

TILTING THE WORKING PLANE

DCM (Dynamic Collision Monitoring)

TCPM FUNCTION (Tool Center Point Management)

BX700, a high precision, 5-axis control vertical machining center that a swivel head with DD Motor on the rotary table to achieves the highest productivity in 5 axis machining.

BUILT-IN 15,000RPM SPINDLE WITH $\pm 120^\circ$ SWING.

B AXIS-SWIVEL HEAD DESIGNED BY DUAL PITCH WORM GEAR SET THAT ARE TEETH BACKLASH ELIMINATION AND TRANSMISSION PERFECTLY.

Movable tool magazine system designed by linear guideway and hydraulic system to move ATC backward over after tools changed. B axis would rotate up to 120° without any interference.



Pinnacle / BX700 5 AXIS MACHINING

BX series machines by Pinnacle offer the latest and most precise 5-axis technology in the market. Simplify setup and production of complex and multi-sided parts without sacrificing precision and accuracy and saving time. Optimized 5-axis concepts meet every requirement and prevail in all industries worldwide BX series designed by Pinnacle that are High rigidity structure to provide widest working range. Hi quality Meehanite casting iron, tempered for stress relief and over HB190 hardness to ensure deformation-free performance year and year.

TABLE	Table Size (mm)	1600 x 700
	Travel Ranges (X x Y x Z mm)	1400 / 710 / 810
	Max. Table Load (kg)	1200
	Spindle Nose to Table Surface (mm)	110~720
	T-slot (W x D x N mm)	18 x 125 x 5
BUILT-IN SPINDLE	Spindle Taper	BT40
	Bearing Inner Diameter (mm)	Ø70
	Spindle Center to Column (mm)	760
	Spindle Speed (rpm)	15000
	Draw Bar Force (kgf)	900 ± 100
	Main Motor (con/30min kw)	15 / 19.4
SWING HEAD	Motor Torque (con/max Nm)	71.6 / 134
	Driver Type	WORM GEAR
	Reduction Ratio	1 : 120
	Tilting Range (deg)	± 120°
	Max. Speed (rpm)	16.6
	Min. Unit	0.001
ROTARY TABLE	Clamp Torque (Nm)	1765
	Working Torque (Nm)	765
	Type	EMBEDDED
	Table Diameter (mm)	Ø630
	Center Bore Diameter (mm)	Ø60
	Rotation Speed (rpm)	50 (DD motor)
AXIS SERVOMOTORS	Min. Index	0.001
	Max. Table Load (kg)	1000
	Rapid Feed Rate (X/Y/Z m/min)	36 / 36 / 24
	Feed Rate (X/Y/Z m/min)	10000
	Rated Torque (X/Y/Z m/Nm)	18.1 / 18.1 / 18.1
	B-Axis Rated Torque (Nm)	11
TOOL MAGAZINE	C-Axis Rated Torque (Nm)	533
	ATC Type	PLATE
	CAM Type	DAUL ARM
	Tool Selection (Bi-direction)	RANDOM
	Tool Storage Capacity (pcs)	24 (32 / 40)
	Max. Tool Diameter (mm)	Ø90 (Ø75)
ACCURACY	Max. Tool Length	250
	Max. Tool Weight	8
	Positioning XYZ linear axis (mm)	0.005
	BC rotary (sec)	10"
MISCELLANEOUS	Repeatability XYZ linear axis (mm)	0.003
	BC rotary (sec)	6"
	Air Requirement (kg/cm ²)	6
	Voltage	380
	Power Requirement (KVA)	20
	Coolant Tank Capacity (L)	300
	Machine Weight (kgs)	12000
	Machine Height (mm)	3200
	Packing Size (L x W x H mm)	3130 x 2300 x 256



5 AXIS VERTICAL MACHINING CENTER

Real powerful 5-axis machining center

Fast and contour-accurate motion guide

High-quality surface

The shortest machining time

BX300A / 500A

PNEUMATIC BALANCE SYSTEM

COOLANT THROUGH BALL SCREWS

CNC CONTROLLER SYSTEM

PLANE FUNCTION

TILTING THE WORKING PLANE

DCM (Dynamic Collision Monitoring)

TCPM FUNCTION (Tool Center Point Management)

BX300 and BX500, a 5-axis control vertical machining center with a swivel head and rotary table design. Rotary table is removable and machine could work as 4 axes machine.

B-AXIS-SWIVEL MILLING HEAD

BUILT-IN 15,000RPM SPINDLE WITH $\pm 120^\circ$ SWING.

B AXIS-SWIVEL HEAD DESIGNED BY DUAL PITCH WORM GEAR SET THAT ARE TEETH BACKLASH ELIMINATION AND TRANSMISSION PERFECTLY.

Movable tool magazine system designed by linear guideway and hydraulic system to move ATC backward over after tools changed. B axis would rotate up to 120° without any interference.



Pinnacle / BX300A / 500A 5 AXIS MACHINING

BX series machines by Pinnacle offer the latest and most precise 5-axis technology in the market. Simplify setup and production of complex and multi-sided parts without sacrificing precision and accuracy and saving time. Optimized 5-axis concepts meet every requirement and prevail in all industries worldwide BX series designed by Pinnacle that are High rigidity structure to provide widest working range. Hi quality Meehanite casting iron, tempered for stress relief and over HB190 hardness to ensure deformation-free performance year and year.

		BX300A	BX500A
TABLE	Table Size (mm)	1300 x 610	1450 x 610
	Travel Ranges (X x Y x Z mm)	1140 / 610 / 810	1300 / 610 / 810
	Max. Table Load (kg)	850	850
	Spindle Nose to Table Surface (mm)	110-920	110-920
	T-slot (W x D x N mm)	18 x 125 x 5	18 x 125 x 5
BUILT-IN SPINDLE	Spindle Taper	BT40	BT40
	Bearing Inner Diameter (mm)	Ø70	Ø70
	Spindle Center to Column (mm)	600	675
	Spindle Speed (rpm)	15000	15000
	Draw Bar Force (kgf)	800 ± 100	800 ± 100
	Main Motor (con/30min kw)	15 / 18	15 / 18
	Motor Torque (con/max Nm)	48 / 120	48 / 120
SWING HEAD	Driver Type	WORM GEAR	WORM GEAR
	Reduction Ratio	1 : 72	1 : 72
	Tilting Range (deg)	± 120°	± 120°
	Max. Speed (rpm)	16.6	16.6
	Min. Unit	0.001	0.001
	Clamp Torque (Nm)	1157	1157
	Working Torque (Nm)	764	764
ROTARY TABLE	Type	SEPARATED	SEPARATED
	Table Diameter (mm)	Ø320	Ø500
	Center Bore Diameter (mm)	Ø70	Ø60
	Rotation Speed (rpm)	22.2	11.1
	Min. Index	0.001	0.001
	Max. Table Load (kg)	350	500
AXIS SERVOMOTORS	Rapid Feed Rate (X/Y/Z m/min)	30 / 30 / 24	30 / 30 / 24
	Feed Rate (X/Y/Z m/min)	10000	10000
	Rated Torque (X/Y/Z m/Nm)	11 / 11 / 11	11 / 11 / 11
	B-Axis Rated Torque (Nm)	11	11
	C-Axis Rated Torque (Nm)	11	11
TOOL MAGAZINE	ATC Type	PLATE	PLATE
	CAM Type	DAUL ARM	DAUL ARM
	Tool Selection (Bi-direction)	RANDOM	RANDOM
	Tool Storage Capacity (pcs)	24 (32 / 40)	24 (32 / 40)
	Max. Tool Diameter (mm)	Ø90 (Ø75) Ø90 (Ø75)	
	Max. Tool Length	250	250
	Max. Tool Weight	8	8
ACCURACY	Positioning XYZ linear axis (mm)	0.005	0.005
	BC rotary (sec)	10"	10"
	Repeatability XYZ linear axis (mm)	0.003	0.003
	BC rotary (sec)	6"	6"
MISCELLANEOUS	Air Requirement (kg/cm ²)	6	6
	Voltage	380	380
	Power Requirement (KVA)	20	20
	Coolant Tank Capacity (L)	300	300
	Machine Weight (kgs)	5300	6500
	Machine Height (mm)	2750	3100
	Floor Space (L x W mm)	3100 x 2230	3400 x 2230
	Packing Size (L x W x H mm)	3150 x 2300 x 2550	3450 x 2300 x 2550

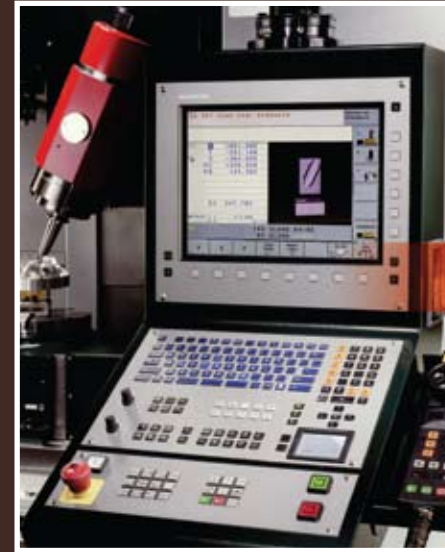

5 AXIS VERTICAL MACHINING CENTER

Real powerful 5-axis machining center

Fast and contour-accurate motion guide

High-quality surface

The shortest machining time

AX450

760 X 610 X 560 MM TRAVEL

A AXIS TILT 220° ($\pm 110^\circ$)

C AXIS ROTARY 360°

RAPID FEEDRATE 30/30/24

9/12 KW SPINDLE MOTOR

ISO40 SPINDLE TAPER

X, Y & Z AXIS LINEAR WAY

The major structural parts are manufactured from high quality Meehanite cast iron (GB 300), tempered for stress relief with hardness over 190HB.

Roller type linear ways on X, Y, Z axis increased stability.

X, Y, Z axis are transmitted with class C3, $\varnothing 40$ mm ball screws.

The major structure parts are manufactured from high quality Meehanite cast iron, tempered for stress relief. The spindle head elevation employs a pneumatic type balance system to minimize the spindle head vibration during moving.

The 5-axis synchronized machining saves machining time, reduces repetitive workpiece setup and error, while dramatically increasing machining and accuracy.



Pinnacle / AX450 5 AXIS MACHINING

Pinnacle AX450 are proven to be super machines for high efficiency and accuracy.

Each Pinnacle machine is subject to dynamic and static accuracy tests.

Pinnacle Machine accuracy meets ISO 10791 VDI 3441, ISO 230, JIS B6388 and ASMEB5 standards.

TABLE	Table Size (mm)	Ø450
	Travel Ranges (X x Y x Z mm)	760 x 610 x 560
	T Slot Size (Size x deg)	14 x 45
	Max. Table Load (kg)	150
	Max. Workpiece Size (W x H mm)	Ø450x Ø300
	Diameter of Table Hole (mm)	Ø171
	Spindle Nose to Table Surface (mm)	55~615
	A Axis, Tilt (deg)/(0.001°)	220°(±110°)
C Axis, Rotary (deg)/(0.001°)	360°	
SPINDLE	Tool Shank & Pull Stud	ISO40
	Spindle Inner Diameter (mm)	Ø70
	Spindle Speed (rpm) Direct drive	10000
	Spindle Speed (rpm) Built-in	15000
	Main Motor (con/30 min Kw)	9/12
AXIS SERVO MOTOR	Rapid Feed Rate (X/Y/Z m/min)	30/30/24
	Feed Rate (X/Y/Z/ m/min)	10
	Feed Rate (A/C rev/min)	5.5/11.5
	X Axis Rated Torque (Nm)	10
	Y Axis Rated Torque (Nm)	10
	Z Axis Rated Torque (Nm)	10
	A Axis Rated Torque (Nm)	10
C Axis Rated Torque (Nm)	10	
AUTO TOOL CHANGER	ATC Type	DISK (CHAIN)
	Cam Type	ARM
	Tool Selection (Bi-direction)	RANDOM
	Tool Storage Capacity (PCs)	24 (32,40)
	Max. Tool Diameter (mm)	Ø90 (Ø76)
	Max. Tool Length	300
	Max. Tool Weight	8
MISCELLANEOUS	Air Requirement (Kg/cm2)	6
	Hydraulic Requirement (Kg/cm2, L)	40, 30L
	Voltage	220
	Power Requirement (KVA)	40
	Coolant Tank Capacity (L)	300
	Machine Weight (KGs)	7000
	Machine Height (mm)	2900
	Floor Space (L x W mm)	3100 x 2230
Packing Size (L x W x H mm)	3100 x 2230 x 2560	

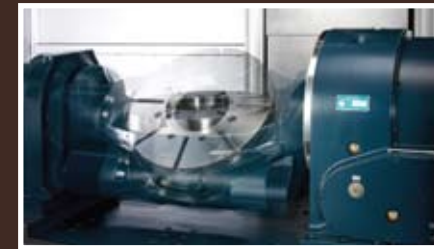

RIGID, STABLE, ACCURATE

Ruggedly Constructed Throughout to Provide Lifetime Accuracy Year After Year

AX320

660 X 610 X 610 MM TRAVEL

A AXIS TILT 150° (-120°/+30°)

C AXIS ROTARY 360°

RAPID FEEDRATE 30/30/24

9/12 KW SPINDLE MOTOR

ISO40 SPINDLE TAPER

X, Y & Z AXIS LINEAR WAY

The major structural parts are manufactured from high quality Meehanite cast iron (GB 300), tempered for stress relief with hardness over 190HB.

Roller type linear ways on X, Y, Z axis increased stability.

X, Y, Z axis are transmitted with class C3, Ø40mm ball screws.

The major structure parts are manufactured from high quality Meehanite cast iron, tempered for stress relief. The spindle head elevation employs a pneumatic type balance system to minimize the spindle head vibration during moving.

The 5-axis synchronized machining saves machining time, reduces repetitive workpiece setup and error, while dramatically increasing machining and accuracy.



Pinnacle / AX320 5 AXIS MACHINING

Pinnacle AX320 are proven to be super machines for high efficiency and accuracy.

Each Pinnacle machine is subject to dynamic and static accuracy tests.

Pinnacle Machine accuracy meets ISO 10791 VDI 3441, ISO 230, JIS B6388 and ASMEB5 standards.

TABLE	Table Size (mm)	Ø320
	Travel Ranges (X x Y x Z mm)	660 x 610 x 610
	T Slot Size (Size x deg)	12 x 90
	Max. Table Load (kg)	100
	Max. Workpiece Size (W x H mm)	Ø320x Ø300
	Diameter of Table Hole (mm)	Ø50
	Spindle Nose to Table Surface (mm)	44~654
	A Axis, Tilt (deg)/(0.001°)	150°[-120°/+30°]
	C Axis, Rotary (deg)/(0.001°)	360°
	SPINDLE	Tool Shank & Pull Stud
Spindle Inner Diameter (mm)		Ø70
Spindle Speed (rpm) Direct drive		10000
Spindle Speed (rpm) Built-in		15000
Main Motor (con/30 min Kw)		9/12
AXIS SERVO MOTOR	Rapid Feed Rate (X/Y/Z m/min)	30/30/24
	Feed Rate (X/Y/Z/ m/min)	10
	Feed Rate (A/C rev/min)	5.5/11.5
	X Axis Rated Torque (Nm)	10
	Y Axis Rated Torque (Nm)	10
	Z Axis Rated Torque (Nm)	10
	A Axis Rated Torque (Nm)	5
	C Axis Rated Torque (Nm)	3.8
AUTO TOOL CHANGER	ATC Type	DISK (CHAIN)
	Cam Type	ARM
	Tool Selection (Bi-direction)	RANDOM
	Tool Storage Capacity (PCs)	24 (32,40)
	Max. Tool Diameter (mm)	Ø90 (Ø76)
	Max. Tool Length	300
	Max. Tool Weight	8
MISCELLANEOUS	Air Requirement (Kg/cm2)	6
	Hydraulic Requirement (Kg/cm2, L)	40, 30L
	Voltage	220
	Power Requirement (KVA)	40
	Coolant Tank Capacity (L)	300
	Machine Weight (KGs)	6500
	Machine Height (mm)	2900
	Floor Space (L x W mm)	2660 x 2230
Packing Size (L x W x H mm)	2660 x 2230 x 2560	



RIGID, STABLE, ACCURATE

Ruggedly Constructed Throughout to Provide Lifetime Accuracy Year After Year

QV147

1140 (1300 / 1400) X 710 X 610 MM

TRAVEL

RAPID FEEDRATE 20/20/16 M/MIN

15HP / 20HP SPINDLE MOTOR

ISO40 SPINDLE TAPER / ISO50

SPINDLE TAPER

X, Y & Z AXIS SQUARE WAY

4 SLIDEWAY ON BASE

Rugged Construction Assures Optimum Rigidity and Stability.

The major structural parts are manufactured from high quality Meehanite cast iron (FC-30), hardened to over HB190 and tempered to relieve stress.

Box ways on the three axes. Way surfaces are hardened to over HRC55 with over 2 mm depth.

Slideway surfaces are coated with Turcite-B and combined with precision scraping.

Three axes are equipped with class C3 and 40mm (QV117 / QV127 / QV147) and 50mm (QV159 / QV179 / QV209) diameter precision ball screws.

Counter-balance weight moves on a guide shaft for added stability and straightness accuracy.



Pinnacle / QV147 HEAVY DUTY VMC

QV's Designed for Extra Value and Built for Optimum Performance

Now you can get the right VMC's with the right features for extra heavy-duty machining, superior stability and excellent rigidity. Pinnacle box way series VMC's are quality constructed throughout for maximum performance dependability - year after year. If you expect a VMC that will provide higher machining efficiency to reduce production costs, then consider placing a dependable, heavy-duty Pinnacle VMC in your production line.

TABLE	Table Size (mm)	1600 x 700
	Travel Ranges (X x Y x Z mm)	1400 / 710 / 610
	Max. Table Load (kgs)	1500
	T-slot (Width x Distance x Number mm)	18 x 125 x 5
SPINDLE	Tool Shank & Pull Stud	ISO50
	Spindle Inner Diameter (mm)	Ø100
	Spindle Nose to Table Surface (mm)	110 ~ 720
	Spindle Center to Column (mm)	760
	Spindle Speed (rpm) Belt	40 - 6000 (8000)
	Spindle Speed (rpm) Gear	L40 ~ 1500, H1501 ~ 6000
	Draw Bar Force (kgf)	2000
	Main Motor (con/30 min Kw)	11 / 15
FEED RATE	Rapid Feed Rate (X/Y/Z m/min)	20 / 20 / 16
	Feed Rate (X/Y/Z) mm/min	10000
AXIS SERVO MOTOR	Mitsubishi (Kw)	HF354 (3.5)
	Fanuc (Kw)	β22/2000is 2.5 (12i/3000i 3.0)
	Siemens (Kw)	1FK7083 (4.17)
	Fagor (Kw)	FXM55.20
	Heidenhain (Kw)	QSY155D (5.68)
AUTO TOOL CHANGER	ISO50	
	Mag Type	DISK / CHAIN
	Cam Type	DAUL ARM
	Tool Selection (Bi-direction)	RANDOM
	Tool Storage Capacity (PCs)	24 / 32
	Max. Tool Diameter (mm)	Ø115 / Ø125
MISCELLANEOUS	Max. Tool Length (mm), Weight (kgs)	350, 20
	Air Requirement (Kg/cm ²)	6
	Voltage	220V, 3Ph, 50 / 60Hz
	Power Requirement (KVA)	30
	Coolant Tank Capacity (L)	200
	Machine Weight (Kgs)	9500
	Machine Height (mm)	3000
Floor Space (L x W mm)	3890 x 3080	



RIGID, PRECISION SPINDLE ASSURES HIGH QUALITY MACHINING

COUNTER WEIGHT BALANCE SYSTEM

Exclusively designed counter weight balance system. The counter-balance weight moves on a guide shaft to assure movement straightness accuracy. There is no vibration in the forward/backwards and in the right/left directions. This creates superior workpiece surface accuracy to meet various mold machining requirements.

QV209

1500 (1700, 2000) X 900 X 850 MM

TRAVEL

RAPID FEEDRATE 16/16/12 M/MIN

25/20HP SPINDLE MOTOR

ISO40 SPINDLE TAPER / ISO50

SPINDLE TAPER

X, Y & Z AXIS SQUARE WAY

4 SLIDEWAY ON BASE

Rugged Construction Assures Optimum Rigidity and Stability.

The major structural parts are manufactured from high quality Meehanite cast iron (FC-30), hardened to over HB190 and tempered to relieve stress.

Box ways on the three axes. Way surfaces are hardened to over HRC50 with over 2 mm depth.

Slideway surfaces are coated with Turcite-B and combined with precision scraping.

Three axes are equipped with class C3 and 40mm (QV117 / QV127 / QV147) and 50mm (QV159 / QV179 / QV209) diameter precision ball screws.

Counter-balance weight moves on a guide shaft for added stability and straightness accuracy.



Pinnacle / QV209 HEAVY DUTY VMC

QV's Designed for Extra Value and Built for Optimum Performance

Now you can get the right VMC's with the right features for extra heavy-duty machining, superior stability and excellent rigidity. Pinnacle box way series VMC's are quality constructed throughout for maximum performance dependability - year after year. If you expect a VMC that will provide higher machining efficiency to reduce production costs, then consider placing a dependable, heavy-duty Pinnacle VMC in your production line.

TABLE	Table Size (mm)	2200 x 850
	Travel Ranges (X x Y x Z mm)	2000 / 900 / 850
	Max. Table Load (kgs)	3000
	Spindle Nose to Table Surface (mm)	150 ~ 1000
	T-slot (Width x Distance x Number mm)	18 x 150 x 5
SPINDLE	Tool Shank & Pull Stud	ISO50
	Spindle Inner Diameter (mm)	Ø100
	Spindle Center to Column (mm)	150~ 1000
	Spindle Speed (rpm) Belt	40 - 6000 (8000)
	Spindle Speed (rpm) Gear	L40 ~ 1500, H1501 ~ 6000
	Draw Bar Force (kgf)	2000
	Main Motor (con/30 min Kw)	15 / 18.5
FEED RATE	Rapid Feed Rate (X/Y/Z m/min)	16 / 16 / 12
	Feed Rate (X/Y/Z) mm/min)	8000
AXIS SERVO MOTOR	Mitsubishi (Kw)	HF703 (7.0)
	Fanuc (Kw)	β30/3000i (7.0)
	Siemens (Kw)	1FK7101 (7.03)
	Fagor (Kw)	FXM75.2 (7.04)
	Heidenhain (Kw)	QSY190D (9.6)
AUTO TOOL CHANGER	ISO50	
	Mag Type	DISK / CHAIN
	Cam Type	DAUL ARM
	Tool Selection (Bi-direction)	RANDOM
	Tool Storage Capacity (PCs)	24 / 32
	Max. Tool Diameter (mm)	Ø115 / Ø125
MISCELLANEOUS	Max. Tool Length (mm), Weight (kgs)	350, 20
	Air Requirement (Kg/cm ²)	6
	Voltage	220V, 3Ph, 50 / 60Hz
	Power Requirement (KVA)	40
	Coolant Tank Capacity (L)	300
	Machine Weight (Kgs)	16000
	Machine Height (mm)	3200
Floor Space (L x W mm)	4750 x 2900	



RIGID, PRECISION SPINDLE ASSURES HIGH QUALITY MACHINING

COUNTER WEIGHT BALANCE SYSTEM

Exclusively designed counter weight balance system. The counter-balance weight moves on a guide shaft to assure movement straightness accuracy. There is no vibration in the forward/backwards and in the right/left directions. This creates superior workpiece surface accuracy to meet various mold machining requirements.

SV105

650(850)(1020) X 560 X 560 MM

TRAVEL

RAPID FEEDRATE 20/20/20 M/MIN

10 HP SPINDLE MOTOR

ISO40 SPINDLE TAPER

SPINDLE SPEED 8,000 RPM

10,000 RPM (OPTION)

DIRECT DRIVE 12,000 RPM (OPTION)

X, Y & Z AXIS BOX WAY

Rugged Construction Assures Optimum Rigidity and Stability.

The major structural parts are manufactured from high quality Meehanite cast iron (FC-30), hardened to over HB190 and tempered to relieve stress.

Box ways on the three axes. Way surfaces are hardened to over HRC55 with over 2 mm depth.

Slideway surfaces are coated with Turcite-B and combined with precision scraping.

Three axes are equipped with class C3 and 36mm (SV65/SV85/SV105) and 40mm (SV96/SV116/SV126) diameter precision ball screws.



Pinnacle / SV105 VMC

SV's Designed for Extra Value and Built for Optimum Performance

Now you can get the right VMC's with the right features for extra heavy-duty machining, superior stability and excellent rigidity. Pinnacle box way SV series are quality constructed throughout for maximum performance dependability - year after year. If you expect a VMC that will provide higher machining efficiency to reduce production costs, then consider placing a dependable, heavy-duty Pinnacle SV series in your production line.

TABLE	Table Size (mm)	1200 x 510
	Travel Ranges (X x Y x Z mm)	1020 x 560 x 560
	Max. Table Load (kgs)	600
	Spindle Nose to Table Surface (mm)	100 ~ 660
	T-slot (Width x Distance x Number mm)	18 x 100 x 5
SPINDLE	Distance Between Column (mm)	ISO40
	Spindle Inner Diameter (mm)	Ø70
	Spindle Center to Column (mm)	600
	Spindle Speed (rpm) Belt	60 ~ 8000 (10,000)
	Spindle Speed (rpm) Gear	L40 ~ 2000, H2001 ~ 8000
	Spindle Speed (rpm) Direct-Drive	12000
	Draw Bar Force (kgf)	950
	Main Motor (con/30 min Kw)	5.5 / 7.5
FEED RATE	Rapid Feed Rate (X/Y/Z m/min)	20 / 20 / 20
	Feed Rate (X/Y/Z) mm/min)	10000
AXIS SERVOMOTOR	Mitsubishi X/Y/Z (Kw)	HF353 (3.5)
	Fanuc (Kw)	Ø22/2,000 i (2.5) or á12/3,000 i (3.0)
	Siemens (Kw)	1FK7 063 (2.9)
	Fagor (Kw)	FKM64.30A
	Heidenhain (Kw)	QSY155B (2.47)
AUTO TOOL CHANGER	ATC Type	PLATE / DISK
	Cam Type	GENOVA / DAUL ARM
	Tool Selection (Bi-direction)	ABSOLUTE / RANDOM
	Tool Storage Capacity (PCs)	20 / 20 (24)
	Max. Tool Diameter (mm)	Ø100 / Ø93 (Ø90)
	Max. Tool Length (mm), Weight (kgs)	250, 8
MISCELLANEOUS	Air Requirement (Kg/cm ²)	6
	Voltage	220
	Power Requirement (KVA)	20
	Coolant Tank Capacity (L)	200
	Machine Weight (Kgs)	5400
	Machine Height (mm)	2650
	Floor Space (L x W mm)	3000 x 2200
Packing Size (L x W x H mm)	3050 x 2200 x 2400	

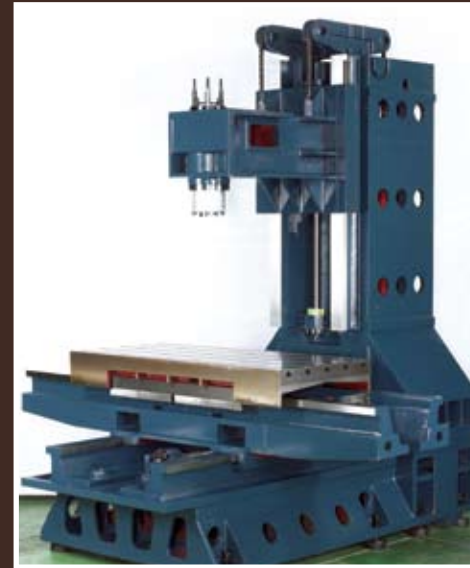

RIGID, PRECISION SPINDLE ASSURES HIGH QUALITY MACHINING

COUNTER WEIGHT BALANCE SYSTEM

Exclusively designed counter weight balance system. The counter-balance weight moves on a guide shaft to assure movement straightness accuracy. There is no vibration in the forward/backwards and in the right/left directions. This creates superior workpiece surface accuracy to meet various mold machining requirements.

LV85

650(850)(1020) X 560 X 560 MM

TRAVEL

RAPID FEEDRATE 30/30/24 M/MIN

10 HP SPINDLE MOTOR

ISO40 SPINDLE TAPER

SPINDLE SPEED 8,000 RPM

10,000 RPM (OPTION),

DIRECT DRIVE 12,000 RPM (OPTION)

X, Y & Z AXIS LINEAR WAY

Rugged Construction Assures Optimum Rigidity and Stability.

The major structural parts are manufactured from high quality Meehanite cast iron (FC-30), hardened to over HB190 and tempered to relieve stress.

High precision and premium quality P class linear guideways way wide block and 35mm (LV65/LV85/LV105) and 45mm (LV96/LV116/LV126)width linear guideways on three axes.

Three axes equipped with class C3 precision and 36mm (LV65/LV85/LV105) and 40mm (LV96/LV116/LV126)diameter ball screws.

RIGID, PRECISION SPINDLE ASSURES HIGH QUALITY MACHINING

Supported by superior precision P4 class bearings, the spindle provides an extra wide range of machining capacity and high speed.



Pinnacle / LV85 LINEAR WAY VMC

LV's Designed for Extra Value and Built for Optimum Performance

When jobs call for highly efficient machining and when outstanding accuracy is critical, a Pinnacle linear way series vertical machining center is the perfect solution. The three axes move on linear guideways that minimize friction while providing high accuracy of positioning and repeatability. This series are not only suitable for large-range production line application. It is also ideal for smaller factories and machine shops. If you are serious about increasing machining productivity and profits, the Pinnacle linear way series LV can really help you.

TABLE	Table Size (mm)	1000 x 510
	Travel Ranges (X x Y x Z mm)	850 x 560 x 560
	Max. Table Load (kgs)	600
	Spindle Nose to Table Surface (mm)	100 ~ 660
	T-slot (Width x Distance x Number mm)	18 x 100 x 5
SPINDLE	Distance Between Column (mm)	ISO40
	Spindle Inner Diameter (mm)	Ø70
	Spindle Center to Column (mm)	600
	Spindle Speed (rpm) Belt	60 ~ 8000 (10,000)
	Spindle Speed (rpm) Gear	L40 ~ 2000, H2001 ~ 8000
	Spindle Speed (rpm) Direct-Drive	12000
	Draw Bar Force (kgf)	950
	Main Motor (con/30 min Kw)	5.5 / 7.5
FEED RATE	Rapid Feed Rate (X/Y/Z m/min)	30 / 30 / 24
	Feed Rate (X/Y/Z mm/min)	10000
AXIS SERVOMOTOR	Mitsubishi X/Y/Z (Kw)	HF353 (3.5)
	Fanuc (Kw)	Ø22/2,000 i (2.5) or á12/3,000 i (3.0)
	Siemens (Kw)	1FK7 063 (2.9)
	Fagor (Kw)	FKM64.30A
	Heidenhain (Kw)	QSY155B (2.47)
AUTO TOOL CHANGER	ATC Type PLATE / DISK	PLATE / DISK
	Cam Type GENOVA / DAUL ARM	GENOVA / DAUL ARM
	Tool Selection (Bi-direction)	ABSOLUTE / RANDOM
	Tool Storage Capacity (PCs)	20 / 20 (24)
	Max. Tool Diameter (mm)	Ø100 / Ø93 (Ø90)
	Max. Tool Length (mm), Weight (kgs)	250, 8
MISCELLANEOUS	Air Requirement (Kg/cm ²)	6
	Voltage	220
	Power Requirement (KVA)	20
	Coolant Tank Capacity (L)	200
	Machine Weight (Kgs)	5200
	Machine Height (mm)	2650
	Floor Space (L x W mm)	2600 x 2200
	Packing Size (L x W x H mm)	2650 x 2200 x 2400

THE BEST POSSIBLE STRUCTURAL DESIGN



COUNTER WEIGHT BALANCE SYSTEM

Exclusively designed counter weight balance system. The counter-balance weight moves on a guide shaft to assure movement straightness accuracy. There is no vibration in the forward/backwards and in the right/left directions. This creates superior workpiece surface accuracy to meet various mold machining requirements.



LV117

950(1140)(1270) X 610 X 610 MM

TRAVEL

RAPID FEEDRATE 30/30/24 M/MIN

15 HP SPINDLE MOTOR

ISO40 (ISO50) SPINDLE TAPER

SPINDLE SPEED 8,000 RPM

10,000 RPM (OPTION)

DIRECT DRIVE 12,000 RPM (OPTION)

X, Y & Z AXIS LINEAR WAY

**The Best Possible Structural Design.
Rugged Construction Assures Optimum
Rigidity and Stability.**

The major structural parts are manufactured from high quality Meehanite cast iron (FC-30), hardened to over HB190 and tempered to relieve stress.

High precision and premium quality P class linear guideways way wide block and 35mm (LV65/LV85/LV105) and 45mm (LV96/LV116/LV126)width linear guideways on three axes.

Three axes equipped with class C3 precision and 36mm (LV65/LV85/LV105) and 40mm (LV96/LV116/LV126)diameter ball screws.

RIGID, PRECISION SPINDLE
ASSURES HIGH QUALITY MACHINING



Pinnacle / LV117 LINEAR WAY VMC

LV's Designed for Extra Value and Built for Optimum Performance

When jobs call for highly efficient machining and when outstanding accuracy is critical, a Pinnacle linear way series vertical machining center is the perfect solution. The three axes move on linear guideways that minimize friction while providing high accuracy of positioning and repeatability. This series are not only suitable for large-range production line application. It is also ideal for smaller factories and machine shops. If you are serious about increasing machining productivity and profits, the Pinnacle linear way series LV can really help you.

TABLE	Table Size (mm)	1300 x 610
	Travel Ranges (X x Y x Z mm)	1140 x 610 x 610
	Max. Table Load (kgs)	850
	Spindle Nose to Table Surface (mm)	110 ~ 720
	T-slot (Width x Distance x Number mm)	18 x 125 x 5
SPINDLE	Distance Between Column (mm)	ISO40
	Spindle Inner Diameter (mm)	Ø70
	Spindle Center to Column (mm)	675
	Spindle Speed (rpm) Belt	60 ~ 8000 (10,000)
	Spindle Speed (rpm) Gear	L40 ~ 2000, H2001 ~ 8000
	Spindle Speed (rpm) Direct-Drive	12000
	Draw Bar Force (kgf)	950
FEED RATE	Main Motor (con/30 min Kw)	7.5 / 11
	Rapid Feed Rate (X/Y/Z m/min)	30 / 30 / 24
FEED RATE	Feed Rate (X/Y/Z mm/min)	10000
	Mitsubishi X/Y/Z (Kw)	HF353 (3.5)
AXIS SERVOMOTOR	Fanuc (Kw)	Ø22/2,000 i (2.5) or á12/3,000 i (3.0)
	Siemens (Kw)	1FK7 063 (2.9)
	Fagor (Kw)	FKM64.30A
	Heidenhain (Kw)	QSY155B (2.47)
AUTO TOOL CHANGER	ISO40	
	ATC Type	PLATE / DISK
	Cam Type	GENOVA / DAUL ARM
	Tool Selection (Bi-direction)	ABSOLUTE / RANDOM
	Tool Storage Capacity (PCs)	20 / 24 (30)
	Max. Tool Diameter (mm)	Ø100 / Ø90 (Ø77)
	Max. Tool Length (mm), Weight (kgs)	250, 8
MISCELLANEOUS	Air Requirement (Kg/cm ²)	6
	Voltage	220
	Power Requirement (KVA)	20
	Coolant Tank Capacity (L)	300
	Machine Weight (Kgs)	6500
	Machine Height (mm)	2950
	Floor Space (L x W mm)	3100 x 2200
	Packing Size (L x W x H mm)	3150 x 2200 x 2350

THE BEST POSSIBLE STRUCTURAL DESIGN



COUNTER WEIGHT BALANCE SYSTEM

Exclusively designed counter weight balance system. The counter-balance weight moves on a guide shaft to assure movement straightness accuracy. There is no vibration in the forward/backwards and in the right/left directions. This creates superior workpiece surface accuracy to meet various mold machining requirements.



LV85APC

APC-Automatic Pallet Changer

Compact design; minimum floor space required.

Rotating motion for pallet change; change time approximately 9 seconds.

Hydraulic rotating mechanism feature fast, stable and reliable operations.

Hollow Ball Screw Cooling System

The hollow cooling system effectively dissipates heat deformation due to high speed ball screw running.



Pinnacle / LV85APC AUTO PALLET VMC

LV's Designed for Extra Value and Built for Optimum Performance

Pinnacle LV-85APC Machining Center, with excellent features, provides perfect machine results and enhanced productivity when it works in conjunction with automatic pallet changer. Hydraulic rotating mechanism features fast, stable and smooth operations. Thanks to its outstanding design, the APC provides best performance over lifetime. When you consider increased efficiency and decreased cost, Pinnacle LV-85APC Machining Center is truly the best choice.

QUALITY THROUGH PRECISION INSPECTIONS

TABLE	Table Size (mm)	850 x 500
	Travel Ranges (X x Y x Z mm)	850 x 560 x 560
	Max. Table Load (kgs)	300
	Spindle Nose to Table Surface (mm)	100 ~ 660
	T-Slot (WxNxP mm)	18 x 100 x 5
	Pallet Change Time (sec)	8
	Pallet Exchange Method	+180°Rotation
	Locking Strength	1500kg@20kg/cm ²
SPINDLE	Spindle Nose	ISO40
	Spindle Inner Diameter (mm)	Ø70
	Spindle Center to Column (mm)	600
	Spindle Speed (rpm) Gear	L40-20 H2001-8000
	Spindle Speed (rpm) Belt	60-8000(10000)
	Draw Bar Force (kgf)	950
	Main Motor (con/30 min Kw)	5.5 / 7.5
FEED RATE	Rapid Feed Rate (X/Y/Z m/min)	32
	Feed Rate (X/Y/Z/ mm/min)	10000
AXIS SERVOMOTOR	Mitsubishi X/Y/Z/ kw	HF354 3.5
	Fanuc	β22/20000 is 2.5 or (á12/3000 i 3.0)
	Siemens	1FK7 063
	Fagor	FKM64 30A
	Heidenhain	QSY155B 2.47
AUTO TOOL CHANGER	ATC Type	PLATE / DISK
	Cam Type	GENOVA / DAUL ARM
	Tool Selection (Bi-direction)	ABSOLUTE / RANDOM
	Tool Storage Capacity (PCs)	20/20(24)
	Max. Tool Diameter (mm)	Ø100/ Ø93 (Ø90)
	Max. Tool Length (mm)	250
MISCELLANEOUS	Max. Tool Weight (Kgs)	8
	Air Requirement (Kg/cm ²)	6
	Voltage	220
	Power Requirement (KVA)	20
	Coolant Tank Capacity (L)	200
	Machine Weight (Kgs)	5200
	Machine Height (mm)	2890
	Floor Space (L x W mm)	4035 x 2200
	Packing Size (L x W x H mm)	3585 x 2300 x 2540



LV500

500 X 350 X 400 MM TRAVEL

RAPID FEEDRATE 32/32/32 M/MIN

5.5KW SPINDLE MOTOR

X, Y & Z AXIS LINEAR WAY

12,000 RPM DIRECT-DRIVE

SPINDLE (ISO40)

**The Best Possible Structural Design
Rugged Construction Assures Optimum
Rigidity and Stability.**

The major structural parts are manufactured from high quality Meehanite cast iron (FC-30), hardened to over HB190 and tempered to relieve stress.

High precision and premium quality P class linear guideways way wide block and 20mm width linear guideways on three axes.

Screw type chip conveyor at front side to remove chips efficiently.

The three axes equipped with class C3 precision and 25mm diameter ball screws.

Oversized high performance AC digital servo motors provide up to 32M per minute rapid traverse assuring smooth consistent power to give a perfect finish.



Pinnacle / LV500 HIGH SPEED VMC

When jobs call for highly efficient machining and when outstanding accuracy is critical, a Pinnacle linear way series vertical machining center is the perfect solution. The LV300B(D) / LV500B(D) is a multifaceted series. It is not only ideal for smaller factories and machine shops. It covers applications ranging from watch and time pieces to 3C and 4C industries. It is also ideal for manufacturing molds for joints, teeth and bones used in the medical industry. If you are serious about increasing machine productivity and profits, the Pinnacle linear way series can really help you.

TABLE	Table Size (mm)	570 x 350
	Travel Ranges (X x Y x Z mm)	500 x 350 x 400
	Max. Table Load (kgs)	200
	Spindle Nose to Table Surface (mm)	30 ~ 430
	T-slot (Width x Distance x Number mm)	14 x 100 x 3
SPINDLE	DIRECT-DRIVE	
	Tool Shank & Pull Stud	BT40/DIN40
	Spindle Inner Diameter (mm)	Ø120
	Spindle Center to Column (mm)	350
	Spindle Speed (rpm)	10000
	Draw Bar Force (kgf)	800
	Main Motor (con/30 min Kw)	5.5
FEED RATE	Rapid Feed Rate (X/Y/Z m/min)	32 / 32 / 32
	Feed Rate (X/Y/Z) mm/min)	10,000
AXIS SERVOMOTOR	Mitsubishi X/Y/Z (Kw)	HF 154T (1.5)
	Fanuc (Kw)	β8i/3000 is (1.8)
	Fagor (Kw)	FXM14.20 (1.86)
	Heidenhain (Kw)	QSY96 (1.4)
AUTO TOOL CHANGER	Mag Type	DISK / PLATE
	Cam Type	GENOVA / DAUL ARM
	Tool Selection (Bi-direction)	ABSOLUTE / RANDOM
	Tool Storage Capacity (PCs)	10 / 20
	Max. Tool Diameter (mm)	Ø115 / Ø65
	Max. Tool Length (mm), Weight (kgs)	150mm, 7kgs
MISCELLANEOUS	Air Requirement (Kg/cm ²)	6
	Voltage	220V, 3Ph, 50 / 60Hz
	Power Requirement (KVA)	10
	Coolant Tank Capacity (L)	170
	Machine Weight (Kgs)	2600
	Floor Space (L x W mm)	1950 x 2130 x 2155

QUALITY THROUGH PRECISION INSPECTIONS

Rigid, Precision Spindle Assures High Quality Machining

Supported by superior precision P4 class bearings, the spindle provides an extra wide range of machining capacity and high speed.

Floating unclamping system assures tool unclamping force will not transmit to the spindle bearings. It provides stable tool clamping and unclamping with the spindle and extends the spindle bearings' life.

The spindle is a cartridge-type.

Choice of various spindle speeds - Direct-drive 12,000 rpm.

Building-in 24,000 rpm.

The circulating oil cooling system on the spindle head prevents thermal expansion and offers the best precision machining environment.

LH500A

500 X 500 TABLE

650 X 560 X 560 MM TRAVEL

INDEX TABLE 1° / 0.001°

11/15 KW SPINDLE MOTOR

CHAIN TYPE 40-TOOL ATC

ISO40 SPINDLE TAPER (GEAR DRIVES)

X, Y, Z AXIS RAPID TRAVERSE

30/30/24 M/M

GEAR BOX This spindle running is transmitted through a gear box, making the machine excellent for heavy cutting applications.

With the gear box, the spindle provides two speed changes. The low speed range is 40~1750rpm, and high speed range is 1751~8000 rpm. The wide speed range permits the machine to perform heavy cutting and fine fine finishing.

All gears and bearings in the gear box are oil-bath lubricated.



Pinnacle / LH500A HMC

EACH PINNACLE MACHINE IS SUBJECT TO DYNAMIC AND STATIC ACCURACY TESTS

TABLE	Table Size & Number (mm)	500 x 500
	Travel Ranges (X x Y x Z mm)	650 x 560 x 560
	Screw size (Size x Pitch mm)	18 x 100 x 5
	Max. Table Load (kg)	400
	Max. Workpiece Size (W x H mm)	Ø630 x 610
	Spindle Center to Table surface (mm)	50
	Spindle Nose to Table Center (mm)	100
	Table Index (deg)	1° (0.001°)
	Method of Pallet Changer	-
	SPINDLE	Spindle Taper
Spindle Inner Diameter (mm)		Ø70
Spindle Speed (rpm) Belt		-
Spindle Speed (rpm) Gear Box		L40~2000, H2001~8000
Spindle Speed (rpm) Direct drive		10000
Spindle Speed (rpm) Built-in		15000
Main Motor (con/30 min Kw)		11/15
AXIS SERVO MOTOR		Rapid Feed Rate (X/Y/Z m/min)
	Feed Rate (X/Y/Z/ m/min)	10
	X Axis Rated Torque (Nm)	10
	Y Axis Rated Torque (Nm)	10
	Z Axis Rated Torque (Nm)	10
	B Axis Rated Torque (Nm)	10
	B Axis Max. Rpm	16.6
AUTO TOOL CHANGER	ATC Type	CHAIN
	Cam Type	ARM
	Tool Selection (Bi-direction)	RANDOM
	Tool Storage Capacity (PCs)	40
	Max. Tool Diameter (mm)	Ø76
	Max. Tool Length	300
	Max. Tool Weight	8
	MISCELLANEOUS	Air Requirement (Kg/cm ²)
Hydraulic Requirement (Kg/cm ² , L)		35, 60L
Voltage		220
Power Requirement (KVA)		40
Coolant Tank Capacity (L)		300
Machine Weight (KGs)		6500
Machine Height (mm)		2425
Floor Space (L x W mm)		3055 x 4560
Packing Size (L x W x H mm)		2200 x 2900 x 2500

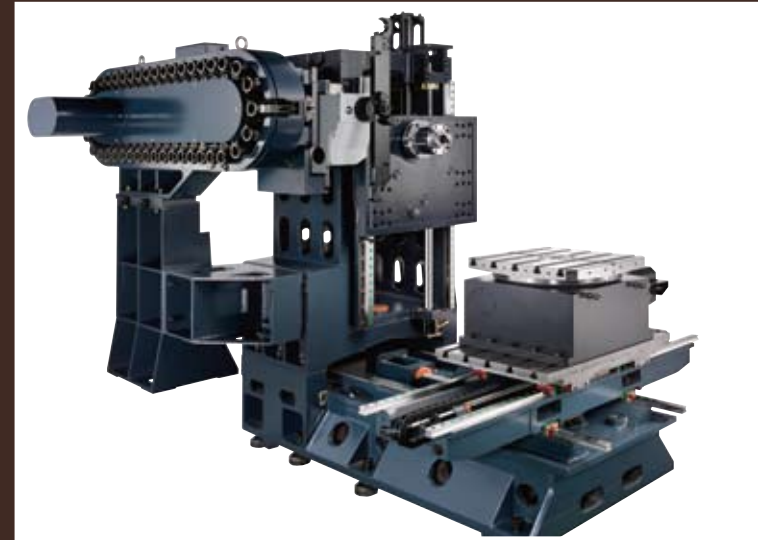

LH500B

500 X 500 TABLE X 2

650 X 560 X 560 MM TRAVEL

INDEX TABLE 0.001° / 1°

11/15 KW SPINDLE MOTOR

AUTOMATIC PALLET CHANGE

CHAIN TYPE 40-TOOL ATC

ISO40 SPINDLE TAPER (GEAR DRIVES)

X, Y, Z AXIS RAPID TRAVERSE

30/30/24 M/MIN

AUTOMATIC PALLET CHANGE

Swing type automatic pallet change features stable construction and smooth change motion.

Pallet change is fast-accomplished in only 8 seconds.

Pallet positions on oversized cones that guarantee high positioning accuracy
Max. pallet loading capacity is 400kg.

HEAVY-CUTTING RESITANCE

The rotary table is designed with hydraulic-expansion circular locking mechanism. During locking, the complete circumference is completely tightened. This results in higher rigidity and increased heavy cutting resistant capability.

GEAR BOX

This spindle running is transmitted through a gear box, making the machine excellent for heavy cutting applications. With the gear box, the spindle provides two speed changes. The low speed range is 40~1750rpm, and high speed range is 1751~8000 rpm.



Pinnacle / LH500B HMC

OPTIMAL STRUCTURE DESIGN

High Rigidity! Exception Stability! Equipped with automatic pallet change.

The major structural parts are manufactured from Meehanite cast iron, hardened to hardness over HB190

The structural parts are tempered for stress relief that ensures deformation-free performance year after year.

X, Y, Z axis are mounted with roller type linear ways, exhibiting extra high rigidity and loading capacity.

Oversized column structure dramatically increases machining stability.

Fixed column construction.

TABLE	Table Size & Number (mm)	500 x 500 x2
	Travel Ranges (X x Y x Z mm)	650 x 560 x 560
	Screw size (Size x Pitch mm)	M16 x 100
	Max. Table Load (kg)	400
	Max. Workpiece Size (W x H mm)	Ø630 x 610
	Spindle Center to Table surface (mm)	50
	Spindle Nose to Table Center (mm)	100
	Table Index (deg)	0.001° (1°)
	Method of Pallet Changer	SWING
	SPINDLE	Spindle Taper
Spindle Inner Diameter (mm)		Ø70
Spindle Speed (rpm) Belt		-
Spindle Speed (rpm) Gear Box		L40~2000, H2001~8000
Spindle Speed (rpm) Direct drive		10000
Spindle Speed (rpm) Built-in		15000
Main Motor (con/30 min Kw)		11/15
AXIS SERVO MOTOR		Rapid Feed Rate (X/Y/Z m/min)
	Feed Rate (X/Y/Z/ m/min)	10
	X Axis Rated Torque (Nm)	10
	Y Axis Rated Torque (Nm)	10
	Z Axis Rated Torque (Nm)	10
	B Axis Rated Torque (Nm)	10
	B Axis Max. Rpm	16.6
AUTO TOOL CHANGER	ATC Type	CHAIN
	Cam Type	ARM
	Tool Selection (Bi-direction)	RANDOM
	Tool Storage Capacity (PCs)	40
	Max. Tool Diameter (mm)	Ø76
	Max. Tool Length	300
	Max. Tool Weight	8
MISCELLANEOUS	Air Requirement (Kg/cm2)	6
	Hydraulic Requirement (Kg/cm2, L)	40, 60L
	Voltage	220
	Power Requirement (KVA)	40
	Coolant Tank Capacity (L)	300
	Machine Weight (KGs)	6700
	Machine Height (mm)	2425
	Floor Space (L x W mm)	3055 x 5445
Packing Size (L x W x H mm)	2200 x 3785 x 2500	

**HIGH RIGIDITY!
EXCEPTIONAL STABILITY!**
EQUIPPED WITH AUTOMATIC PALLET CHANGE.



DV1

To meet the high speed, high precision machining requirement, the DV14 series employs a direct-drive high speed spindle. This combines with a high / low speed gearbox for transmission with the wide speed range. It makes the machine ideal for high speed machining. In addition, the gearbox also provides high torque output, permitting the machine to perform heavy cutting with ease. The spindle head on the DV14 series is designed with advanced automatic compensation balancing system combined with the use of accumulator to control hydraulic cylinder, allowing the spindle to move smoothly and steadily at all times.

ROLLER TYPE LINEAR WAYS ON THREE AXES

All major structural parts are manufactured from high quality cast iron with tempering tread to relieve stress, ensuring maximum material stability without deformation.

Box type structural parts are rib reinforced to increase structural strength and rigidity.

Extra heavy base complete support of table and resists heavy load without deformation.

X, Y, Z axis are mounted with roller type linear ways combined with extra wide between ways for added stability.



Pinnacle / DV1 DOUBLE COLUMN

DV14 series Double Column Machining center that fully combines heavy cutting and high speed machining capabilities in one. The DV14 series is a profitable performer especially excellent for precision machining for extra heavy parts. To ensure maximum stability when handling heavy parts machining, the five major structural parts of the machine are manufactured from high quality Meehanite cast iron and ductile iron. The specially designed machine structure enables the machine to keep at the best accuracy condition after years of operation. With the roller type linear guide ways on X, Y, Z axis, the machine fully exhibits its heavy loading resistance and outstanding features.

TRAVEL	Travel Ranges (X x Y x Z mm)	4200 x 1350 x 900
	Spindle Nose to table Surface (mm)	200~1100
	Spindle Center to Column (mm) 404	404
	Distance between Column (mm)	1400
TABLE	Table Size (mm)	4200 x 1200
	T Slot (W D x N mm)	22 x 150 x7
	Max. Table Load (kg/m2)	8000
SPINDLE	Tool Shank & Pull Stud	ISO50
	Spindle Inner Diameter (mm)	Ø100
	Spindle Speed (rpm) Gear	40-6000
	Draw Bar Force (Kgf)	2000
	Main Motor (con/30 min Kw)	15/18.5
AXIS SERVO MOTOR	Rapid Feed Rate (X/Y/Z m/min)	12/20/20
	Feed Rate (X/Y/Z) mm/min)	10000
	Mitsubishi (X/Y/Z/ kW)	HF703 7.0
	Fanuc	β30/3000i 7.0
	Siemens	1FK7 103 4.4
	Fagor	FXM75.20
AUTO TOOL CHANGER	Heidenhain	QSY 190D 9.6
	ATC Type	Chain
	Cam Type	Arm
	Tool Selection (Bi-direction)	Random
	Tool Storage Capacity (PCs)	32
	Max. Tool Diameter (mm)	Ø125/ Ø250
MISCELLANEOUS	Max. Tool Length	350
	Max. Tool Weight	15
	Air Requirement (Kg/cm2)	6
	Hydraulic Requirement (Kg/cm2, L)	40, 40L
	Voltage	220
	Power Requirement (KVA)	50
	Coolant Tank Capacity (L)	900
	Machine Weight (KGs)	19000
Machine Height (mm)	3500	
Floor Space (L x W mm)	10000 x 3000	

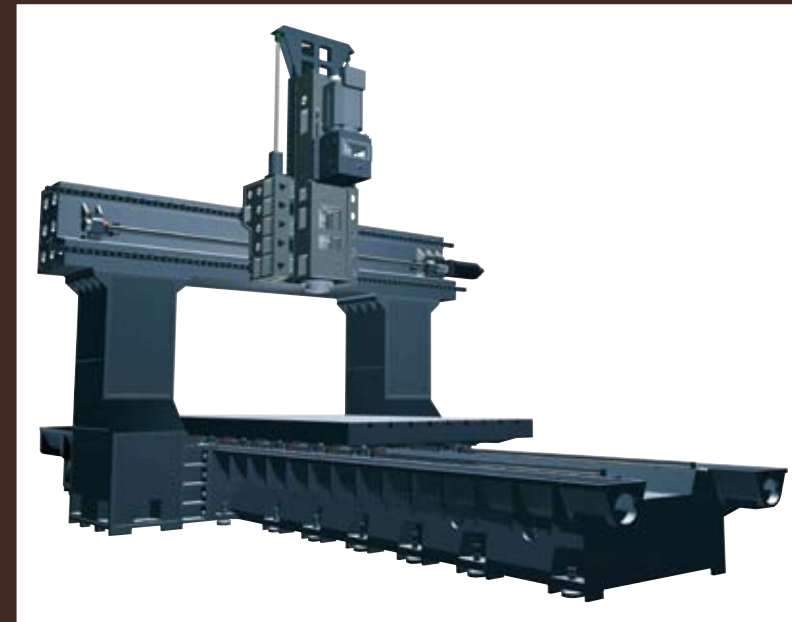

RIGID SPINDLE HEAD

The spindle head is a box-type construction that increases stability when performing heavy loading.

The linear ways on Z axis are specially designed with side layout to upgrade rigidity of the spindle head.

GEAR BOX

This spindle running is transmitted through a gear box, making the machine excellent for heavy cutting applications.

Wide spindle speed range from 10 to 6,000 rpm permit the machine to perform heavy cutting and fine finishing.

All gears and bearings in the gear box are oil-bath lubricated.

32 TOOLS CHAIN TYPE MAGAZINE (STANDARD)

The magazine is driven by a precision cam, featuring fast and accurate tool positioning.

Tool selection is bi-directional and random for fast tool change

The magazine accepts ISO 50 tool shank.

The magazine is separately mounted from the cutting area combined with a protection door to prevent tools contamination from chips or coolant.

DV2

EXCELLENT STRUCTURAL STRENGTH

OPTIMAL SPINDLE HEAD

OUTSTANDING FEED SYSTEM

OUTSTANDING Z-AXIS BALANCING

EXTRA POWER CUTTING CAPABILITY

Excellent Structural Strength : The structural parts are designed by means of "Finite Element Analysis" to achieve the maximum rigidity and dampening capability. This will avoid resonance that may affect machining accuracy while extending tool service life and machining performance.

Optimal Spindle Head : The spindle head is designed with the optimal rectangular structure ratio (1:1.25) permitting Z-axis to achieve the best machining rigidity. The interior of the spindle head is properly spaced combined with circular rib reinforcement, which significantly upgrades cutting rigidity and stability.

Outstanding Z-axis Balancing System : Designed with two-direction balancing circuit combined with two hydraulic counter-balance cylinders, the transmission mechanism of the balancing system is firmly fastened to the Z-axis. This special design ensures accurate response on Z-axis servo motor and meets the requirement of high thrust force.

Outstanding Feed System : The X, Y, Z-axis are mounted with high precision P-class linear guideways featuring 0.003~0.005 extra low friction co-efficiency, minimum sticking and high moving sensitivity. This also results in higher accuracy.



Pinnacle / DV2 DOUBLE COLUMN

Outstanding Feed System Construction : Three axes feeds are transmitted through class C3 precision ball screws, pretensioned at both ends to reduce screw thermal displacement to a minimum. The entire machine employs absolute coordinate system to eliminate complexity of structure. Both ends of ball screw are provided with colliding protection devices.

Extra Powerful Cutting Capability : The BT50 spindle has a diameter of $\varnothing 100$ mm and is supported by class D4 angular contact ball bearings. Maximum spindle speed is 6,000 rpm. The powerful spindle motor provides great torque output combined with the use of 1:4 ZF-2K 250 gearbox with high / low speed ranges. This powerful drive system provides sufficient horsepower and torque output to suit various machining conditions.

DISTANCE BETWEEN COLUMNS	mm	2150
TABLE SIZE	Length (mm)	5300
	Width (mm)	1800
T-SLOT	Width x No. x Pitch (mm)	22x7x250
TRAVEL	X-Axis (mm)	5200
	Y-Axis (mm)	2100
	Z-Axis (mm)	800
SPINDLE	Nose to Table (mm)	375~1175
	Center to Column (mm)	427
	Taper / Speed / Power rpm-kw	BT50-6000-18.5/22
X, Y, Z FEEDRATE	Cutting mm/min	5-8000
	Rapid mm/min	15/15/15
ACCURACY	Positioning / Repeatability (mm)	±0.003 / 300
ATC & TOOL MAGAZINE	Capacity / Dia. / Length (mm)	24 pcs / max. dia. Ø125 (full tools), Ø220 (adjacent pocket empty) / max. length 400
	Max. Tool Weight (Kg)	20(25)
	Tool Selection	Take shortest direction
	MAXIMUM LOAD (ton)	15
MACHINE SIZE	Length (mm)	12400
	Width (mm)	4850
	Height (mm)	4850
	MACHINE WEIGHT (ton)	50

CNC DOUBLE COLUMN MACHINING CENTER

EXCELLENT STRUCTURAL STRENGTH



SV DOUBLE COLUMN

EXCELLENT STRUCTURAL STRENGTH

OPTIMAL SPINDLE HEAD

OUTSTANDING FEED SYSTEM

OUTSTANDING Z-AXIS BALANCING

EXTRA POWER CUTTING CAPABILITY

Excellent Structural Strength : The structural parts are designed by means of "Finite Element Analysis" to achieve the maximum rigidity and dampening capability. This will avoid resonance that may affect machining accuracy while extending tool service life and machining performance.

Optimal Spindle Head : The spindle head is designed with the optimal rectangular structure ratio (1:1.25) permitting Z-axis to achieve the best machining rigidity. The interior of the spindle head is properly spaced combined with circular rib reinforcement, which significantly upgrades cutting rigidity and stability.

Outstanding Z-axis Balancing System : Designed with two-direction balancing circuit combined with two hydraulic counter-balance cylinders, the transmission mechanism of the balancing system is firmly fastened to the Z-axis. This special design ensures accurate response on Z-axis servo motor and meets the requirement of high thrust force.

Outstanding Feed System : The X, Y, Z-axis are mounted with high precision P-class linear guideways featuring 0.003~0.005 extra low friction co-efficiency, minimum sticking and high moving sensitivity. This also results in higher accuracy.



Pinnacle / SV DOUBLE COLUMN

Outstanding Feed System Construction : Three axes feeds are transmitted through class C3 precision ball screws, pretensioned at both ends to reduce screw thermal displacement to a minimum. The entire machine employs absolute coordinate system to eliminate complexity of structure. Both ends of ball screw are provided with colliding protection devices.

Extra Powerful Cutting Capability : The BT50 spindle has a diameter of $\varnothing 100$ mm and is supported by class D4 angular contact ball bearings. Maximum spindle speed is 6,000 rpm. The powerful spindle motor provides great torque output combined with the use of 1:4 ZF-2K 250 gearbox with high / low speed ranges. This powerful drive system provides sufficient horsepower and torque output to suit various machining conditions.

DISTANCE BETWEEN COLUMNS (mm)		5450
TABLE SIZE	Length (mm)	each 1m increase from 6m to 36m
	Width (mm)	4600
T-SLOT	Width x No. x Pitch (mm)	28 x 400
TRAVEL	X-Axis (mm)	each 1m increase from 6m to 36m
	Y-Axis (mm)	5400
	Z-Axis (mm)	1100 (1400)
SPINDLE	Nose to Table (mm)	820~1920 (820~2220)
	Center to Column (mm)	473
	Taper / Speed / Power rpm-kw	BT50-6000-22/26 (30/37)
X, Y, Z FEEDRATE	Cutting (mm/min)	5-8000
	Rapid (mm/min)	10 / 12 / 12
ACCURACY	Positioning / Repeatability (mm)	± 0.005 / 300 ±0.003 / 300
ATC & TOOL MAGAZINE	Capacity / Dia. / Length (mm)	24 pcs / max. dia. Ø125 [full tools], Ø220 [adjacent pocket empty] / max. length 400
	Max. Tool Weight (mm)	28 (35)
	Tool Selection (Kg)	Take shortest direction
	MAXIMUM LOAD (ton)	2500
MACHINE SIZE	Width (mm)	8100
	MACHINE WEIGHT (ton)	137 up

CNC DOUBLE COLUMN MACHINING CENTER

EXCELLENT STRUCTURAL STRENGTH

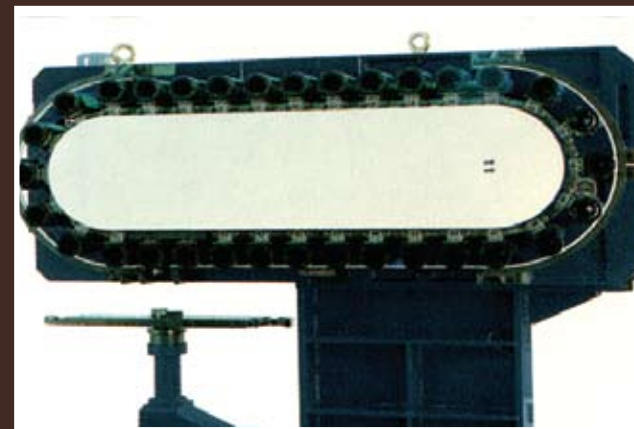
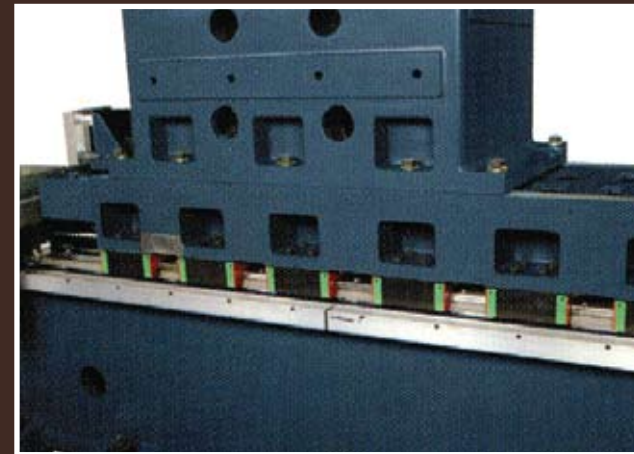

B3KCNC

BT40 SPINDLE, 8000 RPM

HIGH RIGID PRECISION SPINDLE DRIVEN BY 3.75 HP POWERFUL MOTOR

60" X 12" WORKING TABLE WITH GROUND T-SLOTS

EXCELLENT FOR HEAVY WORKPIECES

HARDENED AND GROUND SQUARE SLIDE WAYS AND MATING SURFACES ARE COATED WITH TURCITE-B

TABLE	Table Size (mm)	1524 x 305
	Travel Ranges (X/Y/Z mm)	1020 x 510 x 510
	Max. Table Load (Kgs)	300
	Spindle Nose to Table Surface (mm)	150 - 660
	T-Slot (WxDxN mm)	16 x 63.5 x 3
SPINDLE	Spindle Speed (rpm)	8000
	Main Motor (kW)	7.5
	Spindle Shank & Pull Stud	BT40
AXES	Rapid Feed Rate (X/Y/Z m/min)	10
	Feed Rate (mm/min)	10
	Servomotor X/Y/Z kw	1.5
	MISTUBISHI	HF154 (1.5)
	FANUC	β12/3000is (1.8)
	FAGOR	FKM44.3A (3.6)
AUTO TOOL CHANGER	ATC Type	Disk / Plate
	CAM Type	Daul Arm / Genova
	Tool Storage Capacity (PCs)	20 / 16
	Max. Tool Diameter (mm)	Ø90
	Max. Tool Length	250
MISCELLANEOUS	Max. Tool Weight	8
	Air Requirement (Kg/cm ²)	6
	Voltage	220
	Power Requirement (KVA)	15
	Coolant Tank Capacity (L)	90
	Machine Weight (Kgs)	2700
	Machine Height (mm)	2400
	Floor Space (LxWxH mm)	2400 x 168



Pinnacle / B3KCNC

PKB3K



Pinnacle / PKB3K

X, Y, Z AXES DRIVEN BY INVERTER MOTOR
NT #40 SPINDLE TAPER
90° SWIVEL ANGLE FOR HEAD
HIGH RIGID PRECISION SPINDLE DRIVEN BY 5 HP POWERFUL MOTOR
60" X 12" WORKING TABLE WITH GROUND T - SLOTS
EXCELLENT FOR HEAVY WORKPIECES
HARDENED AND GROUND SQUARE SLIDE WAYS AND MATING SURFACES
ARE COATED WITH TURCITE - B

TABLE		1524x 305mm
TRAVEL	Longitudinal	1020 mm
	Cross	510mm
	Vertical	510mm
	Spindle Travel	127mm
SPINDLE	Taper	NT40#
	Variable Speed	75-4200 RPM
	16-speed-range transmission (optional)	
	Low Range	Low 60, 95, 150, 225
		High 535, 825, 1320, 1930
	High Range	Low 120, 195, 305, 450
		High 1500, 1640, 2620, 3820
Infinitely variable speed transmission (optional) 75 - 3800 RPM		
Quill Feeds Per Rev. of Spindle	0.045, 0.086, 0.142 mm	
Main Motor for Inverting	3.7KW, 3PH	
Swivel Angle to Right & Left	90°	
Approximate Net Weight	2350 Kgs	
Floor Space [L x D x H]	2400 x 1680 x 2150 mm	

L210A

HEAVY DUTY RIGID DESIGN AND CONSTRUCTION

RIGID MEEHANITE CAST IRON CONSTRUCTION PROVIDES CONSISTENT, DEFORMATION-FREE PRECISION MACHINING.

The major parts are manufactured from high quality Meehanite cast iron and are tempered to relieve stress.

The ruggedly constructed base is scientifically rib reinforced for maximum stability during turning.

Extra wide box ways on the X and Z axes way surfaces are hardened, precision ground and coated with Turcite-B for outstanding wear resistance.

The 45 slant bed design features an extremely firm support for the turret and added chip removal efficiency.

RIGID SPINDLE

Supported by superior precision high speed angular ball bearings to provide extra wide range machining capacity and increase rigidity, as well as extends the spindle bearing life.

HYDRAULIC CHUCK

The hydraulic chuck is controlled by a foot switch for efficient and convenient operations.

10-POSITION SERVO TURRET

The rigid turret features outstanding stability while turning.

The turret can be mounted with 25 x 25 mm. O.D. tools and 40 mm. boring tools.



Pinnacle / L210A

SLANT BED CNC TURNING CENTER

With the Pinnacle Slant Bed CNC turning center you get full capabilities to produce the ultimate in heavy-duty turning, maximum efficiency and lifetime accuracy. You also get advanced design concepts that enable you to reduce time cycles to create more profit. When you select a Pinnacle CNC turning center, you get more than just a quality machine, you also get the Pinnacle tradition of excellence.

Swing Over Bed (mm)	Ø520
Swing Over Cross Slide (mm)	Ø250
Distance Between Center (mm)	610
Max. Turning Dia. (mm)	Ø360
Max. Turning Length (mm)	530
Spindle Motor (kw)	11 / 15
Spindle Speed (rpm)	45 - 4,500
Spindle Nose	A2-6
Chuck Dia. or Collet	8"
Dia. Hole Through Spindle (mm)	Ø77
Bar Capacity (mm)	Ø65
Spindle Bearing I.D. (mm)	Ø110
Tailstock Taper	MT4
Tailstock Quill Dia. x Travel (mm)	Ø80 x Ø80
Feed Motor X/Z (kw)	2.0 / 2.0
Travel X/Z (mm)	210 / 610
Rapid Speed X/Z (m/min)	20 / 24
Cutting Feed (mm/min)	0.016 ~ 5,000
Tool Stations Number on Turret	10 / 12
Turret Index Time (T-T) sec	0.13 / 0.11
Tool Size (mm)	25
Boring Tool Dia. (mm)	Ø40
Hydraulic Pump Motor (kw)	1.5
Coolant Pump Motor (kw)	0.53
Lubrication Pump Motor (w)	-
Floor Space LxWxH (M)	2.7 x 1.6 x 1.8
Machine Weight (kg)	3,700

WITH A PINNACLE SLANT BED CNC TURNING CENTER, YOU CAN SEE THE DIFFERENCE IN PERFORMANCE AND QUALITY.



Also available with CM&Y axis

PKFV3 / V2

THE RIGID AND PRECISION SPINDLE IS DRIVEN BY A POWERFUL INVERTER MOTOR

HIGH RIGID PRECISION SPINDLE DRIVEN BY 5 HP POWERFUL MOTOR

NT40# SPINDLE TAPER

THE X AND Y AXES SLIDWAYS ARE COATED WITH TURCITE - B

THE X, Y AND Z AXES SLIDWAYS AND TOP OF WORKING SURFACE ARE HARDENED AND GROUND

SQUARE SLIDWAYS ON COLUMN AND KNEE

MODEL		PK-FV2	PK-FV3
TABLE	Table size (mm)	1372 x 254	1372 x 254
	TRAVEL		
TRAVEL	Longitudinal (mm)	900	900
	Cross (mm)	380	380
	Vertical (mm)	380	380
	Spindle Travel (mm)	127	127
SPINDLE	Taper	NT40#	NT40#
	Dia. of Quill (R.P.M.)	70 - 4200	70 - 4200
	Spindle Speed (mm)	0.04 - 0.08 - 0.15	0.04 - 0.08 - 0.15
	Main Motor for Inverting	3.7 Kw 3PH	3.7 Kw 3PH
	Inverter	3.7 Kw 3PH	3.7 Kw 3PH
	Swivel Angle to Right & Left	90°	90°
	Swivel Angle to Front & Back	45°	45°
	Approximate Net Weight	1450 Kgs	1450 Kgs



Pinnacle / PKFV3 / V2

PK-GRSMV / B



Pinnacle / PK-GRSMV / B

3HP VARIABLE SPEED HEAD
 NT30# / R8 SPINDLE TAPER
 3HP POWERFUL MOTOR
 SQUARE SLIDEWAYS ON KNEE.
 EXTRA WIDE TABLE WORKING AREA 50" X 10"
 HARDENED AND GROUND X,Y AXES AND TABLE SURFACE

MODEL	PK-GRSMV	
TABLE	Table size (mm)	1270 x 254
TRAVEL	Longitudinal (mm)	800
	Cross (mm)	380
	Vertical (mm)	380
	Spindle Travel (mm)	127
SPINDLE	Taper	R8 or NT30#
	Variable Speed (R.P.M.)	75-3800 R.P.M.
	Quill Feeds Rev. Rev. of Spindle	0.04 - 0.08 - 0.15 mm
	Main Motor	2.2 KW 3PH or 3.7 KW 3PH
	Swivel Angle to Right & Left	90°
	Swivel Angle to Front & Back	45°
	Approximate Net Weight	1350 Kgs

MODEL	PK-GRSMB		
TABLE	Table size (mm)	1270 x 254	
TRAVEL	Longitudinal (mm)	800	
	Cross (mm)	380	
	Vertical (mm)	380	
	Spindle Travel (mm)	127	
SPINDLE	Taper	R8 or NT30#	
	Low Range	Low	60, 95, 150, 225
		High	535, 825, 1320, 1930
	High Range	Low	120, 195, 305, 450
		High	1055, 1640, 2620, 3820
	Quill Feeds Rev. Rev. of Spindle	0.04 - 0.08 - 0.15 mm	
	Main Motor	2.2 KW, 3PH or 3.7 KW, 3PH	
	Swivel Angle to Right & Left	90°	
	Swivel Angle to Front & Back	45°	
	Approximate Net Weight	1350 Kgs	

PK-1½GRM-KV / KB

VARIABLE SPEED HEAD

NT30# / R8 SPINDLE TAPER

3HP POWERFUL MOTOR

DOVETAIL SLIDEWAYS

HARDENED AND GROUND X,Y AXES AND TABLE SURFACE

MODEL	PK-1½GRM-KV	
TABLE	Table Size (mm)	1067 x 228 or 1245 x 228
TRAVEL	Longitudinal	680 mm
	Cross	355 mm
	Vertical	406 mm
	Spindle Travel	127 mm
SPINDLE	Taper	R8 or NT30#
	Variable Speed - Variable	70 - 3800 RPM
	Quill Feeds Rer. Rev. of Spindle	0.04 - 0.08 - 0.15 mm
	Main Motor	1.5KW 3PH or 2.2 KW 3PH
	Swivel Angle to Right & Left	90°
	Swivel Angle to Front & Back	45°
	Approximate Net Weight	950 Kgs

MODEL	PK-1½GRM-KB	
TABLE	Table Size (mm)	1067 x 228 or 1245 x 228 mm
TRAVEL	Longitudinal	680 mm
	Cross	355 mm
	Vertical	406 mm
	Spindle Travel	127 mm
SPINDLE	Taper	R8 or NT30#
	16-SPEED RANGE SPINDLE	Low Range
High Range		Low 120, 195, 305, 450 High 1055, 1640, 2620, 3820
Quill Feeds PER. REV. of Spindle		0.04 - 0.08 - 0.15 mm
Main Motor		1.5KW 3PH or 2.2 KW 3PH
Swivel Angle to Right & Left	90°	
Swivel Angle to Front & Back	45°	
Approximate Net Weight	950 kgs	



Pinnacle / PK-1½GRM-KV / KB

TEACH LATHE



Pinnacle / TEACH LATHE

The Pinnacle Tech-in CNC Lathe is designed and built with one thought in mind which customers have come to expect. It delivers high efficiency, hi accuracy, easy operation and multifunction.

It is a perfect lathe that assures greater productivity, lower parts costs and really cuts machining downtime.

RIGID MEEHANITE CAST IRON AND HEAT TREAT HARDENED CONSTRUCTION

BOX WAYS SURFACES ARE HARDNESS AND PRECISION GROUND

SPINDLE IS SUPPORTED WITH 3 POINTS BEARINGS WITH HARDENED AND GROUND GEAR. LUBRICATION AND GEAR OIL BATHING SYSTEM TO ENSURE THE ACCURACY

MODEL	TL460N	TL890A
CAPACITY		
Swing over bed (mm)	Ø460	Ø900
Swing over cross slide (mm)	Ø230	Ø600
Centre height	230	445
Distance between centre (mm)	1000 / 1500 / 2000	1500 / 2000 / 3000 / 4000 / 5000
Bed width (mm)	350	480
SPINDLE		
Spindle nose	D 1-6	A 1-11 or D 1-11
Spindle speeds (rpm)	H: 681 – 1300	H1: 541 – 1200
	M: 151 – 680	H2: 166 – 540
	L: 30 – 150	L1: 76 – 165 L2: 25 – 75
Spindle bore (mm)	Ø56	Ø104 / 155 / 230 (Opt)
Chuck size	8"	12" / 15" (Opt)
TURRET		
Longitudinal travel (Z axis) (mm)	910 / 1410 / 1910	1305 / 1800 / 2800 / 3800 / 4800
Cross slide travel (X axis) (mm)	375	400
Top slide width (mm)	110	280
Size of tool post shank (mm)	25 x 25	32 x 32
X axis rapid travel (m/min)	5	5
Z axis rapid travel (m/min)	7	10
TAILSTOCK		
Tailstock diameter (mm)	Ø68	Ø105
Tailstock travel (mm)	180	150
Tailstock taper	MT 5	MT 5
MOTOR		
Spindle motor (HP)	7.5 (10 – OPT)	20 (25 – OPT)
Drives (X, Z)	DC SERVO	AC SERVO
Range of feeds in manual mode (m/rev)	0.01 – 500	0.01 – 500
Coolant pump motor (HP)	1/8	1/8
Machine weight	2700 / 3000 / 3300	5000 / 5500 / 6500 / 7500 / 8500



EcoCa Product Range

**"Win in quality, excel in service"
is Ecoca's quality policy. Ecoca
insist on producing high-quality
products.**

Since the establishment of the company, Ecoca have devoted themselves to the development and production of lathes. Their product line expanded from conventional lathes to teach-in lathes, and CNC lathes. In addition to simple 2-axis lathes, they developed big capacity slant-bed lathes and CNC lathes with Y axis functions over the years. In June, 2009, Ecoca launched their machining center production line and started the production of vertical machining centers and double-column machining centers. With such a complete product line, they hope to cover most demands in the metal cutting industries.

High quality products result from professional R&D, sincere assembly, and strict QC effects. Ecoca's young and highly efficient staff enable them to adapt to the changes in the industry and meet various demands of their customers. In addition to the high quality products, they also provide customers with excellent service and technical support.

Endless improvements to meet the ever changing world markets. In order to meet the rapid changes in the global markets. Ecoca react swiftly in information collecting, product development, and strategic alliances. They also make internal improvements in management, R&D, and employee education to maintain a competitive advance in the industry.

MT 208

BOTH SQUARE AND LINEAR GUIDE WAYS CAN BE PROVIDED IN THE MT-2 SERIES TO MEET VARIOUS MACHINING REQUIREMENTS OF MACHINE USERS.

30 DEGREE SLANT BED DESIGN FOR EASY OPERATION AND EASY CHIP REMOVAL.

BIG DIAMETER BEARING PROVIDES HIGH RIGIDITY.

MODEL	MT 208	MT208MC
SWING OVER BED (mm)	525	525
SWING OVER CROSS SLIDE (mm)	384	384
MAX. TURNING DIA. (mm)	350	250
MAX. TURNING LENGTH (mm)	500/750	500/750
CHUCK SIZE (inch)	8	8
SPINDLE DRIVE MOTOR (kw)	7.5/9	7.5/9
SPINDLE SPEED RANGE (rpm)	4800	4800
MILLING SPEED RANGE (rpm)	-	4000
NO. OF TOOL STATIONS	6(I.D. tool)+6(O.D. tool)	12
GUIDEWAYS	HARD RAIL	HARD RAIL
MACHINE WEIGHT (N.W.) (Ton.)	3900/4600	3900/4600



Ecoca / MT208

MT 308CS / 308MCSY



Ecoca / MT-308CS / 308MCSY

MT-308MCSY is latest design of MT-series, a multi-task turning centre, featuring with C-axis, live tool, twin spindles and Y axis to achieve high efficiency in both turning and milling performance.

INNOVATIVE 3RD GUIDE WAY DESIGN IS APPLIED TO Z AXIS. PROVIDING MORE SUPPORT FOR Y AXIS SADDLE AND REDUCING SUSPENDED AREA TO INCREASE THE CUTTING PERFORMANCE.

WIDER SADDLE DESIGN RESULTING IN BETTER RIGIDITY.

ORTHOGONAL Y AXIS DESIGN.

MODULIZE DESIGN. OFFERING VARIOUS COMBINATIONS OF CHUCK SIZES, TURNING LENGTHS AND TYPES OF SUB-SPINDLE GUIDE WAYS.

RIGID TAPPING AS STANDARD FUNCTION

INTELLIGENT COMMUNICATION TECHNOLOGY (ICT) AS OPTION.

SWING OVER BED (MM)	600
OVER CROSS SLIDE (MM)	400
MAX TURNING DIA (MM)	286
MAX WORK LENGTH (MM)	900
DRAW TUBE DIA (MM)	52
CHUCK SIZE (INCH)	8"
SPINDLE DRIVE MOTOR (KW)	18.5/22
SPINDLE / MILLING SPEED RANGE (RPM)	4000
SPINDLE NOSE (ASA)	A2-6
THROUGH SPINDLE HOLE DIA (MM)	62
FRONT BEARING DIA (MM)	100
SPINDLE TAPER	1/20
X AXIS TRAVEL (MM)	290
Z AXIS TRAVEL (MM)	970
Y AXIS TRAVEL (MM)	±60
X / Z / Y AXIS MOTORS (KW)	3.0
X / A / Y AXIS RAPID TRAVERSE (M/MIN)	24
GUIDE WAYS	HARDEN RAIL
NO OF TOOL STATIONS	12
SIZE OF EXTERNAL TURNING TOOL (MM)	25
BORING BAR DIA (MM)	40
SUB SPINDLE DRIVE MOTOR (KW)	5.5/7.5
SUB SPINDLE SPEED RANGE (RPM)	6000
SUB SPINDLE NOSE (ASA)	A2-5
SUB CHUCK SIZE (INCH)	6"
SUB SPINDLE TRAVEL (MM)	1010
ELECTRICAL POWER SUPPLY (KVA)	50
COOLANT TANK CAPACITY (L)	150
COOLANT FLOW (L)	20
TOTAL HEIGHT (MM)	2150
FLOOR SPACE (LENGTH x WIDTH) (MM)	5000 x 2010
NET WEIGHT (kg)	5800

MT 310 / 312MC

MODEL	MT 310	MT312MC
SWING OVER BED (mm)	600	600
SWING OVER CROSS SLIDE (mm)	400	400
MAX. TURNING DIA. (mm)	450	330
MAX. TURNING LENGTH (mm)	490/740/990	490/730/980
CHUCK SIZE (inch)	10	12
SPINDLE DRIVE MOTOR (kw)	15/18.5	15/18.5
SPINDLE SPEED RANGE (rpm)	4200	3200
MILLING SPEED RANGE (rpm)	-	3800
NO. OF TOOL STATIONS	12	12
GUIDEWAYS	HARD RAIL	HARD RAIL
MACHINE WEIGHT (N.W.) (Ton.)	4800/5300/5800	4900/5400/5900

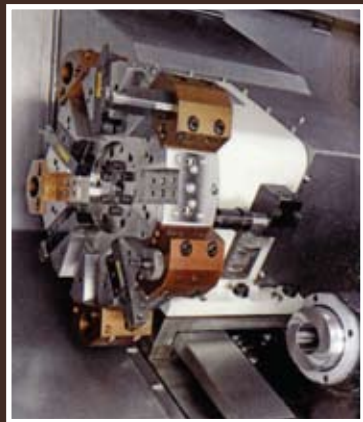

Ecoca / MT310 / 312MC

MT 412 / 415



700MM SWING WITH 3-METER TURNING LENGTH.

AN ECONOMIC CHOICE FOR BIG TURNING PARTS.

SERVO TURRET OR HYDRAULIC TURRET IS OFFERED FOR USERS AS AN ALTERNATIVE CHOICE.

LARGE DISC. IS EQUIPPED FOR EASY TOOL SET UP.

45 DEGREE SLANT BED DESIGN FOR EASY OPERATION AND EASY CHIP REMOVAL.

MODEL	MT 412	MT 415
SWING OVER BED (mm)	700	700
SWING OVER CROSS SLIDE (mm)	500	500
MAX. TURNING DIA. (mm)	510	510
MAX. TURNING LENGTH (mm)	750/1000/1500 /2000/2980	700/950/1450 /1950/2930
CHUCK SIZE (inch)	12	15
SPINDLE DRIVE MOTOR (kw)	18.5/22	18.5/22
SPINDLE SPEED RANGE (rpm)	3200	2500
MILLING SPEED RANGE (rpm)	-	-
NO. OF TOOL STATIONS	12	12
GUIDEWAYS	HARD RAIL	HARD RAIL
MACHINE WEIGHT (N.W.) (Ton.)	6400/7300/8100 /9300/11800	6400/7300/8100 /9300/11800

Ecoca / MT412 / 415



MT 518 / 520MC

1 METER SWING WITH 5 METER CUTTING LENGTH MEETS THE TREND FOR BIGGER AND LONGER TURNING DEMANDS.

45 DEGREE BED SLANTNESS PROVIDES GOOD CHIP DISPOSAL FUNCTION NECESSARY FOR BIG TURNING JOBS.

HIGH-RIGIDITY TURRET WITH STURDY PROGRAMMABLE TAILSTOCK AND STEADY REST (OPTIONAL) PROVIDES STRUCTURE WITH MASSIVE RIGIDITY.

MODEL	MT 518	MT 520MC
SWING OVER BED (mm)	1000	1000
SWING OVER CROSS SLIDE (mm)	700	600
MAX. TURNING DIA. (mm)	800	730
MAX. TURNING LENGTH (mm)	2100 / 3100 4100 / 5100	2100 / 3100 4100 / 5100
CHUCK SIZE (inch)	18	20
SPINDLE DRIVE MOTOR (kw)	37/45	37/45
SPINDLE SPEED RANGE (rpm)	124-496(L) 1800(H)	124-496(L) 1500(H)
MILLING SPEED RANGE (rpm)	-	3000
NO. OF TOOL STATIONS	12	12
GUIDEWAYS	HARD RAIL	HARD RAIL
MACHINE WEIGHT (N.W.) (Ton.)	16.5/18.5 20.5/22.5	17.5/19.5 21.5/23.5



Ecoca / MT518 / 520MC



30 DEGREE SLANT DESIGN PROVIDES TURNING
STABILITY AND EASY CHIP REMOVAL

EMPLOYING FANUC SERIES SPINDLE AND AXIAL SERVO MOTORS

LINEAR GUIDEWAYS ON BOTH AXES TO REDUCE
MACHINING TIME AND INCREASE ACCURACY

MODEL	SL 8	SL 8P
SWING OVER BED (mm)	420	420
SWING OVER CROSS SLIDE (mm)	350	350
MAX. TURNING DIA. (mm)	320	320
MAX. TURNING LENGTH (mm)	500	500
CHUCK SIZE (inch)	8	8
SPINDLE DRIVE MOTOR (kw)	7.5/11	11/15
SPINDLE SPEED RANGE (rpm)	4800	4800
NO. OF TOOL STATIONS	12	12
GUIDEWAYS	LINEAR	LINEAR
MACHINE WEIGHT (N.W.) (Ton.)	3350	3380

EL1 / SJ

ONE PIECE CAST BASE STRUCTURE FOR MAXIMUM STIFFNESS AND VIBRATION DAMPING.

COMBINING THE MERITS OF CONVENTIONAL LATHES AND CNC LATHES, THIS MACHINE IS SUITABLE FOR BIG AND LONG WORK PIECES TURNING OPERATIONS.

SEPARATE COOLANT TANK AND REMOVABLE CHIP TANK ALLOW THE OPERATORS TO CLEAN THE COOLANT AND CHIPS.

MODEL	EL-4610	EL-4615
SWING OVER BED (mm)	460	460
SWING OVER CROSS SLIDE (mm)	285	285
CENTER HEIGHT (mm)	225	225
DIS.BETWEEN CENTERS (mm)	1000	1500
SPINDLE DRIVE MOTOR (kw)	5.5	5.5
SPINDLE SPEED RANGE (rpm)	HIGH	690-3000
	MEDIUM	250-1000
	LOW	95 ~ 350
SPINDLE NOSE	D1-6	D1-6
MACHINE WEIGHT (N.W.) (kg.)	1850	2470

MODEL	SJ-560X1500G	SJ-660X3000G
SWING OVER BED (mm)	560	660
SWING OVER CROSS SLIDE (mm)	339	433
DIS. BETWEEN CENTERS (mm)	1524	3024
SWING OVER GAP (mm)	785	890
WIDTH OF BED (mm)	350	400
SPINDLE NOSE	ASA D1-8 (or ASA A1-8)	ASA D1-11 (or ASA A2-11)
SPINDLE BORE (mm)	82	105
TAPER OF SPINDLE BORE	MT#7	MT#7
SPINDLE SPEED RANGE (rpm)	15~1500 (changes)	15~1500 (changes)
INCH TREADS RANGE	P0.5~P14	P0.5~P14
LONGITUDINAL FEEDS RANGE (mm)	0.05~0.8	0.05~0.8
CROSS FEEDS RANGE (Mm)	0.02~0.36	0.02~0.36
LEADSCREW DIA. (mm)	38	38
LEADSCREW PITCH	6mm (or 4 T.P.I.)	6mm (or 4 T.P.I.)
TAPER OF TAILSTOCK QUILL	MT#5	MT#5
TAILSTOCK QUILL TRAVEL (mm)	165	165
TAILSTOCK QUILL DIA. (mm)	75	85
SPINDLE MOTOR (HP)	10	10
COOLANT PUMP (HP)	1/8	1/8
MACHINE WEIGHT (N.W.) (mm)	2300	3350



Ecoca / EL1 / SJ



SUPPORTED BY HEAVY-DUTY LINEAR GUIDEWAYS
 HIGH-RIGIDITY AND STRONG STRUCTURE TO ENHANCE MACHINING
 PERFORMANCE AND LONG MACHINE LIFE
 3-AXIS WITH PRELOAD AND PRE-TENSIONED LARGE DIAMINATION AND
 PRECISION BALL SCREWS

MODEL	VB-850	VB-2000
TABLE SIZE (mm)	1050x510	2100x850
MAX. TABLE LOAD (kg)	700	3000
X/Y/Z AXIS TRAVEL(mm)	850/610/610	2000/810/700
SPINDLE MOTOR (kw)	7.5/11	15/18.5
SPINDLE TAPER	BT-40	BT-40
SPINDLE SPEED (rpm)	8000 - BELT DRIVE	8000 - BT DRV
RAPID TRAVERSE RATES (X/Y/Z) (m/min)	20/20/15	15/15/15
DISC-TYPE & TOOL STORAGE CAPACITY	ARMLESS / 16T	ARMLESS / 24T
GUIDEWAYS	HARD RAIL	HARD RAIL
MACHINE WEIGHT (N.W.) (kg)	6600	17200

Ecoca / VBi / VLi / V-1000BC



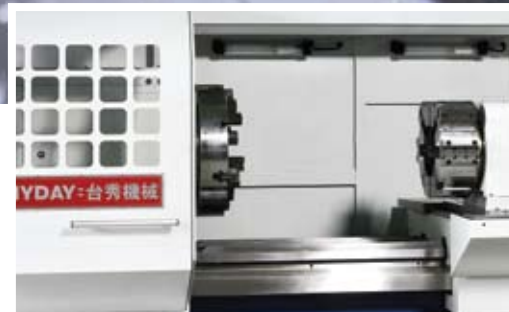

Myday Product Range

We emphasize pursuit of excellence and customer satisfaction more than growth in revenue and profit.

Since the foundation of the company, Myday have been committed to creating and providing the most cost effective (maximum functionality at the minimum cost) products and services to the whole world.

Myday are a professional manufacturer of Heavy Duty Lathes & CNC lathes.

Myday have a strong R&D department which can accept customer's special requirements.

CNC Oil Country Lathe : 22" Bed Specifications

BED WIDTH: 560/ 800MM

SWING: 960~1600MM

BORE: 156~535MM

MODEL	TNC-960		TNC-1060		
SWING OVER BED (mm)	960		1060		
SWING OVER CROSS SLIDE (mm)	530		630		
BED WIDTH (mm)	560 (22")				
DISTANCE BETWEEN CENTERS (mm)	1500-6000 (60"-240")				
SPINDLE BORE (mm)	Ø156	Ø230	Ø260	Ø310	Ø360
SPINDLE NOSE	A2-11	A2-15	A2-15	A2-20	A2-20
SPINDLE SPEEDS (4 STEPS) (RPM)	6-800	4-600	4-600	3-400	3-400
SPINDLE MOTOR	22KW (BC 1.5-5M) / 30KW (BC 6M)				
BALL SCREW DIAMETER	X-axis : Ø40 , Z-AXIS : Ø63 (BC 1.5-5M) / Ø80 (BC 6M)				
CUTTING SPEED (m/min)	X-axis : 0-5 Z-AXIS : 0-5		X-axis : 0-5 Z-AXIS : 0-5		
MAX, X-AXIS TRAVEL (mm)	600		600		
MAX, Z-AXIS TRAVEL (mm)	1250-5750		1250-5750		
TAILSTOCK SPINDLE TRAVEL/QUILL	300 / Ø140		300 / Ø140		
TAILSTOCK SPINDLE TAPER (mm)	MT#6		MT#6		
CONTROLLER	FAGOR 8055i		FANUC 0i-TD		
X-AXIS SERVO MOTOR	FXM 54		12i		
SERVO MOTOR OUTPUT (KW)	2.8		3.0		
Z-AXIS SERVO MOTOR	FXM 74		a22i		
SERVO MOTOR OUTPUT (KW)	5.3		4.0		
COOLANT PUMP MOTOR	1HP		1HP		



Myday / CNC Oil Country Lathe

CNC Oil Country Lathe is a famous product line for oil & gas fielding and metal industry. It could be big bore lathe of double chucks at both sides of the headstock, or it could have large swing for big workpiece. It could be applied to oil pipes, big steel rollers, large diameter flanges, long shafts of ships, etc. Besides, for better workpiece clamping, we have rotary quill option on tailstocks.



Myday / Heavy Duty Lathe

Heavy Duty Precision Lathe is a very popular product line in metal industry. The spindle motor power in the series is transmitted to the spindle through pulley, belt and 4-step gear sets. It could perform heavy duty machining with high speed and high rigidity.

Heavy Duty Lathe - 16" Bed Specifications

Bed Width: 400/ 460mm

Swing: 600~840mm

Bore: 80~230mm

MODEL	3A-24	3A-33
CENTER HEIGHT (mm)	300	420
SWING OVER BED (mm)	600	840
SWING OVER CROSS SLIDE (mm)	390	630
SWING OVER GAP (mm)	820	1060
WIDTH OF GAP (mm)	460	
WIDTH OF BED (mm)	400	
DISTANCE BETWEEN CENTERS (mm)	1500 , 2000 , 3000 , 4000 , 5000	
SPINDLE BORE (mm)	Ø80	Ø104
SPINDLE NOSE	A1-8, D1-8	A2-11, D1-11
SPINDLE SPEEDS (12 STEPS)	17-1200 RPM	15-1000 RPM
TAILSTOCK QUILL DIAMETER (mm)	Ø80	
TAPER OF CENTER	MT#5	
QUILL TRAVEL (mm)	230	
TOOL SIZE (mm)	25 X 25	
COMPOUND REST TRAVEL (mm)	230	
CROSS SLIDE TRAVEL (mm)	300	385
CROSS FEEDS (mm)	0.025-0.35 (36 KINDS)	
LONGITUDINAL FEEDS (mm)	0.05-0.7 (36 KINDS)	
LEAD SCREW DIAMETER (mm)	Ø45	
LEAD SCREW PITCH (mm)	2TPI (INCH) OR 12MM (METRIC)	
THREADING RANGE, METRIC	0.8-14 MM / PITCH (65 KINDS)	
THREADING RANGE, INCH	2-28 TPI (36 KINDS)	
MODULE PITCH THREADS	0.5-7 M (22 KINDS)	
DP. PITCH THREADS	4-56 P (36 KINDS)	
MAIN SPINDLE MOTOR	15 HP	
COOLANT PUMP	1/8 HP	

4 Guide-way Giant Lathe Specifications

BED WIDTH: 1345MM

SWING: 800~2500MM

BORE: 230MM

MODEL	3A-70	3A-100
CENTER HEIGHT (mm)	900 MM	1250 MM
SWING OVER BED (mm)	1800 (70")	2500 (98.4")
SWING OVER CROSS SLIDE:		
FULL LENGTH (STD.) (mm)	1350	2050
SWING OVER CROSS SLIDE:		
HALF LENGTH (OPT.) (mm)	1530	2200
WIDTH OF BED (mm)	1345 (52.9") (4 GUIDE WAY)	
DISTANCE BETWEEN CENTERS (mm)	3000 ~ 12000 (120~480")	
SPINDLE BORE / NOSE (mm)	Ø230 (9") / A2-15	
SPINDLE SPEED(4 STEPS)	6 ~400	
TAILSTOCK QUILL DIAMETER (mm)	Ø290 HEAVY DUTY ROTARY QUILL	
TAPER OF CENTER	MT#7	
QUILL TRAVEL (mm)	300	
CROSS FEEDS	0.056 ~ 0.96 (48 KINDS)	
CROSS TRAVEL (mm)	1250 (FULL LENGTH) OR 510 (HALF LENGTH)	
LONGITUDINAL FEEDS	0.13 ~ 1.92 (48 KINDS)	
COMPOUND REST TRAVEL (mm)	X1: 250 Z1: 400MM (AUTO FEEDING)	
TOOL SIZE (mm)	50 X 50	
LEAD SCREW DIAMETER (mm)	Ø60	
LEAD SCREW PITCH	2TPI (INCH) OR 12MM (METRIC)	
THREADING RANGE, METRIC	2 ~ 30 MM / PITCH (48 KINDS)	
THREADING RANGE, INCH	1 ~ 15 TPI (48 KINDS)	
MODULE PITCH THREADS	1 ~ 15 M (32 KINDS)	
DP. PITCH THREADS	2 ~ 30 MM (48 KINDS)	
MAIN SPINDLE MOTOR	60 HP (STD.) OR 75 HP (OPT.)	
RAPID MOTOR (HP)	2	
COOLANT PUMP (HP)	1	
LUBRICATION PUMP (W)	12	
MACHINE WEIGHT (3 METER BC) (KG)	28000	30500
WEIGHT PER EXTRA METER (KG)	4500	



Myday / Giant Heavy Duty Lathe

4 Guide-way Giant Lathe is a special type of flat bed lathe. It has one wide bed and 2 pairs of guide ways. Its tailstock and steady rests are placed on the pair of guide ways at the rear side. Thus, we would build the carriage across the 4 guide ways (called full length cross slide) as standard model; this model could stand for very heavy duty machining and has full cross slide travel.

Besides, we could build its carriage on one pair of guide way at the front side (called half length cross slide). In this option, the carriage wouldn't interfere with steady rests and its tailstock; it's very good at outer diameter machining at one time without removing steady rests.



CNC Heavy Duty Precision Lathe - 16" Bed Specifications

Bed Width: 400/ 460mm

Swing: 600~840mm

Bore: 80~230mm

MODEL	TNC-600			TNC-770
SWING OVER BED (mm)	600			770
SWING OVER CROSS SLIDE (mm)	310			480
BED WIDTH (mm)	400 (16")			
DISTANCE BETWEEN CENTERS (mm)	1500 (60")	2000 (80")	3000 (120")	
SPINDLE BORE (mm)	Ø80			Ø104
SPINDLE NOSE	A1-8, D1-8, A2-11			
SPINDLE SPEEDS (4 STEPS) (RPM)	16-1500			13-1200
SPINDLE MOTOR	15 HP			15 KW
BALL SCREW DIAMETER	X-axis : Ø32 , Z-axis : Ø50			
CUTTING SPEED (m/min)	X-axis : 0-5		X-axis : 0-5	
MAX X-AXIS TRAVEL	350 MM			
MAX Z-AXIS TRAVEL (mm)	1300 (60")	1800 (80")	2800 (120")	
TAILSTOCK SPINDLE TRAVEL / QUILL (mm)	230 / Ø95			
TAILSTOCK SPINDLE TAPER	MT#5			
CONTROLLER	FAGOR 8035	FAGOR 8055I	FANUC 0I-TD	FANUC 0I-MATE-D
SPINDLE MOTOR	15 HP		15 KW	
X-AXIS SERVO MOTOR	FXM 32	FANUC A18		FANUC B18
X-AXIS SERVO MOTOR OUTPUT (KW)	2.0		1.2	
Z-AXIS SERVO MOTOR	FXM 34	FANUC A12		FANUC B12
Z-AXIS SERVO MOTOR OUTPUT (KW)	3.2		1.8	
COOLANT PUMP MOTOR (HP)	1/4		1/4	

Myday / CNC Heavy Duty Lathe

CNC Heavy Duty Precision Lathe is a very popular product line in metal industry. The spindle motor power in the series is transmitted to the spindle through pulley, belt and 12-step gear sets. It could perform heavy duty machining with high speed and high rigidity.



Sanco Product Range

The most suitable machines which meet all kinds of demands.

Sanco machine & tools corp. , founded in 1981, is a professional machine tool manufacturer whose products cover a full range of double column machining centers, vertical & horizontal machining centers, cnc/ conventional horizontal boring & milling machines.

Sanco have more than 25 years of experience in machine tool development and production. With more than 2000 units sold worldwide prove that our products are highly appreciated by our customers.

SHM-11025R Specifications

ROTARY TABLE

MOVING COLUMN

TABLE SIZE 1400 X 1600MM

MODEL	SHM-11025R	
TABLE	Overall Size (mm)	1400*1600
	T Slots (mm)	24 x 7
	Height from Ground (mm)	1225
	Maximum Loading (kg)	7000
	B Axis Mini. Increment	0.001° Automatic 4 positions (90°)
TRAVEL	X Axis Travel (mm)	2500
	Y Axis Travel (mm)	1800 (2000 / 2300 / 2500)
	Z Axis Travel (mm)	1500 (1700)
	W Axis Travel (mm)	500 (700)
SPINDLE	Diameter (mm)	Ø110
	Speed (rpm)	5-2500
	Taper	ISO NO. 50 7 / 24
FEED RATE	Rapid Feedrate X / Y / Z (mm/min)	10000
	Rapid Feedrate W (mm/min)	5000
	Minimum Setting (mm/min)	0.001
	Cutting Feedrate (mm/min)	5000
MOTOR	30Min. / Sequent (kW)	18.5 / 15 (26 / 22)
	Axis X / Y / Z / W / B (kW)	7 / 7 / 9 / 3 / 4.2
ATC (AUTO TOOL CHANGER)	No. of ATC (Tools)	40 (60 / 90 / 120)
	Taper	MAS BT-50 (DIN69871)
	Pull Stud	MAS P50T-1 (DIN69872)
	Tool Selection	Absolute type
	Tool Change (Tool to Tool) Sec.	15
	Diameter of Max. Tool (mm)	Ø125 / Ø250
	Max. Tool Length (mm)	400
	Max. Tool Weight (kg)	25
MISCELLANEOUS	Power Supply (KVA)	45
	Hydraulic Tank Volume (L)	260
	Coolant Tank Volume (L)	400
	Lubrication Unit (L)	8
	Machine Dimension (mm)	L:6870 (7070) W:5510 H:4300 (4500 / 4800 / 5000)
	Machine Weight (Approx) (kg)	32000
	CNC Controller	21iMB



Sanco / SHM-W Series



SHM-11020RF Specifications



Sanco / SHM-W Series



ROTARY TABLE

FIXED COLUMN

TABLE SIZE 1000 X 1200MM

MODEL	SHM-11020RF	
TABLE	Overall Size (mm)	1000*1200
	T Slots (mm)	22 x 9
	Height from Ground (mm)	1240
	Maximum Loading (kg)	4000
	B Axis Mini. Increment	0.001° Automatic 4 positions (90°)
TRAVEL	X Axis Travel (mm)	2000
	Y Axis Travel (mm)	1600
	Z Axis Travel (mm)	1200 (1400)
	W Axis Travel (mm)	400
SPINDLE	Diameter (mm)	Ø110
	Speed (rpm)	5-2500
	Taper	ISO NO. 50 7 / 24
FEED RATE	Rapid Feedrate X / Y / Z (mm/min)	10000
	Rapid Feedrate W (mm/min)	5000
	Minimum Setting (mm/min)	0.001
	Cutting Feedrate (mm/min)	5000
MOTOR	30Min. / Sequent (kW)	18.5 / 15 (26 / 22)
	Axis X / Y / Z / W / B (kW)	7 / 7 / 7 / 3 / 7
ATC (AUTO TOOL CHANGER)	No. of ATC (Tools)	40 (60 / 90 / 120)
	Taper	MAS BT-50 (DIN69871)
	Pull Stud	MAS P50T-1 (DIN69872)
	Tool Selection	Absolute type
	Tool Change (Tool to Tool) Sec.	15
	Diameter of Max. Tool (mm)	Ø125 / Ø250
	Max. Tool Length (mm)	400
Max. Tool Weight (kg)	25	
MISCELLANEOUS	Power Supply (KVA)	45
	Hydraulic Tank Volume (L)	260
	Coolant Tank Volume (L)	400
	Lubrication Unit (L)	8
	Machine Dimension (mm)	L:6870 (7070) W:5510 H:4300 (4500 / 4800 / 5000)
	Machine Weight (Approx) (kg)	21000
CNC Controller	21MB	

SHM-13030R / 13040R Specifications

ROTARY TABLE

MOVABLE COLUMN

TABLE SIZE 2000 X 1800MM

MODEL	SHM-13030R / 13040R	
TABLE	Overall Size (mm)	2000 x1800
	T Slots (mm)	28 x 9
	Height from Ground (mm)	1430
	Maximum Loading (kg)	15000
	B Axis Mini. Increment	0.001° Automatic 4 positions (90°)
TRAVEL	X Axis Travel (mm)	3000 (4000 SHM-13040R)
	Y Axis Travel (mm)	2500 (3000)
	Z Axis Travel (mm)	1700
	W Axis Travel (mm)	700 (900)
SPINDLE	Diameter (mm)	Ø130
	Speed (rpm)	2000
	Taper	7 / 24
FEED RATE	Rapid Feedrate X / Y / Z (mm/min)	10000
	Rapid Feedrate W (mm/min)	2000
	Minimum Setting (mm/min)	0.001
	Cutting Feedrate (mm/min)	5000
MOTOR	30Min. / Sequent (kW)	22 / 26
	Axis X / Y / Z / W / B (kW)	9 / 7 / 9 / 3 / 7
ATC (AUTO TOOL CHANGER)	No. of ATC (Tools)	40 (60 / 90 / 120)
	Taper	MAS BT-50
	Pull Stud	MAS P50T-1
	Tool Selection	Absolute type
	Tool Change (Tool to Tool) Sec.	15
	Diameter of Max. Tool (mm)	Ø125 / Ø245
	Max. Tool Length (mm)	400
	Max. Tool Weight (kg)	35
MISCELLANEOUS	Power Supply (KVA)	55
	Hydraulic Tank Volume (L)	260
	Coolant Tank Volume (L)	400
	Lubrication Unit (L)	8
	Machine Dimension (mm)	L: 7700 W: 7800 H: 5200
	Machine Weight (Approx) (kg)	42000 (46000 SHM-13040R)
	CNC Controller	32i-B



Sanco / SHM-W Series



SBM-2000L Specifications

HIGH RIGIDITY MACHINE, SUITABLE FOR HEAVY DUTY CUTTING

HIGH OUTPUT TORQUE

OUTSTANDING DESIGN REFLECTING EXTRAORDINARY CAPABILITES



Sanco / SBM Series

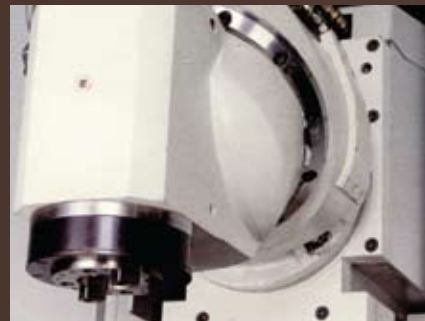

MODEL	SBM-2000L	
TABLE	Working Area (mm)	2100 x 1000
	T Slots (size * no) (mm)	22H8 * 7 slots
	Floor To Table Top (mm)	1005
	Max. Loading (kg)	5000
TRAVEL (W/O OPTIONAL MILLING HEAD HORIZONTAL)		
	X Axis (mm)	2000
	Y Axis(upward-downward) (mm)	1200 (1500)
	Z Axis(frontward-rearward) (mm)	1000
TRAVEL (WITH OPTIONAL MILLING HEAD)		
	X Axis (mm)	2000
	Y Axis(frontward-rearward) (mm)	1000
	Z Axis(upward-downward) (mm)	1200 (1500)
HORIZONTAL SPINDLE		
	Taper	DIN69871 / BT50
	Speed (rpm)	4000 (6000)
	Max. Power Output (kW)	15 / 18.5 (22 / 26)
FEEDRATE		
	Cutting (mm/min)	1-5000
	Rapid (m/min)	10000
BALLSCREWS		
	X Axis Dia. * Pitch (mm*mm)	Ø 63*10
	Y Axis Dia. * Pitch (mm*mm)	Ø 50*10
	Z Axis Dia. * Pitch (mm*mm)	Ø 50*10
	Precision (mm/mm)	0.008 / 300
ACCURACY		
	Positioning (mm)	ISO:X Axis:0.02, YZ Axis:0.015 VID:X Axis:0.02, YZ Axis:0.015
	Repeatability	ISO:X Axis:0.015, YZ Axis:0.011 VID:X Axis:0.015, YZ Axis:0.013
GENERAL		
	Machine Net Weight (kg)	10500
	Pneumatic Required (kg/cm ²)	6
	Hydraulic Required (kg/cm ²)	3.5
	Power Required (kVA)	40kVA

L Series Lathe

Selective bed width:

S series: 300mm

M series: 350mm

L series: 400mm

Varied spindle bore diameters:

S series: Ø58mm / Ø78mm(Optional)

M series: Ø85mm

L series: Ø85mm / Ø115mm(Optional)

With imported bearings installed on spindle, maximum cutting depth can be 8mm and roundness reaching 0.003mm (200mm long).

Equipped with plastic rear gears, shafts and gears inside headstock are well protected if crash should occur. (S series)
Thermal treated and precision ground alloy gears.

Universal gearbox for both imperial and metric threading – converting table also attached.

Tracks of cross slide and bed are well lubricated with lubrication pump (manual).

Overload device to ensure safely when operating.

Wear-resistant phosphor bronze lead screw nuts.

Double reservoir oil bath type cross slide. (for S series)

Thermal treated Meehanite cast bed, hardness of bed reaching HS70.

One-piece base with high rigidity and low vibration.

High-capacity coolant tank offers sufficient coolant output.



Winho / L Series Lathe

	L2240	L2260	L2280	L2210	L22120	L22160
Swing Over Bed (mm)	560 [22"]					
Swing Over Cross Slide (mm)	340 [13-1/3"]					
Center Height (mm)	280 [11"]					
Distance Between Centers (mm)	1000	1500	2000	2500	3300	4300
Swing Over Gap (mm)	788 [31"]					
Width Of Bed (mm)	400 [15-3/4"]					
Spindle Nose	ASA D1 - 8 / D1 - 11 [Opt.]					
Spindle Bore (mm)	85 [3-1/3"] / 115 [4-1/2"] [Opt.]					
Taper of Spindle Bore	MT 7					
Range of Spindle Speed	15 ~ 1500 R.P.M. [12 steps] / 10 ~ 1000 R.P.M. [12 steps, Opt.]					
Inch Threads Range	2 ~ 56 T.P.I.					
Metric Threads Range	P 0.5 ~ P 14					
Longitudinal Feeds Range (mm)	0.05 ~ 0.82 [0.002-0.032"]					
Cross Feeds Range (mm)	0.02 ~ 0.4 [0.001-0.0094"]					
Leadscrew Diameter (mm)	38 [1-1/2"]					
Leadscrew Pitch	4 T.P.I. or 6 mm					
Taper of Tail Center	MT 5					
Tail Spindle Travel (mm)	165 [6-1/2"]					
Tail Spindle Diameter (mm)	85 mm [3-1/3"]					
Main Drive Motor	10 HP [7.5KW] / 10HP [7.5KW, 6P, Opt.]					
Coolant Pump	1/8 HP [0.1KW]					
Compound Rest Travel (mm)	200 [8"]					
Cross Slide Travel (mm)	375 mm [14-3/4"]					
Net Weight (kg)	2200	2550	2900	3150	3620	4830
Gross Weight (kg)	2300	2650	3050	3300	3770	5030
Machine Dimensions (cm)	L2240	238 x 103 x 126	Packing Dimension (cm)		250 x 115 x 194	
	L2260	290 x 103 x 126			300 x 115 x 194	
	L2280	347 x 103 x 126			356 x 115 x 194	
	L2210	398 x 103 x 126			426 x 115 x 194	
	L22120	473 x 103 x 126			485 x 115 x 194	
	L22160	555 x 103 x 126			573 x 115 x 194	



TPX611B

TPX61 series digital readout horizontal boring milling machine is a universal machine tool, which can be adapted to machine casting, steel, and nonferrous work-pieces. Operations include drilling, hole enlarging, boring, reaming, plane milling, spot facing, threading, and other machining processes.

Today, SMTCL horizontal boring milling machine is widely used in the industries of energy, metallurgy, mining, machinery, military, etc., becoming a reliable choice for machining box-type parts.

MODEL	TPX611B		
SPINDLE	SPINDLE DIAMETER (mm)	110	
	SPINDLE TAPER	MORSE NO6 (ISO7:24N050)	
	MAX. SPINDLE TORQUE N.M	1225	
	MAX. SPINDLE THRUSTN	12250	
	NUMBER OF SPINDLE SPEED	22	
	RANGE OF SPINDLE SPEED (RPM)	8-1000	
	POWER OF MAIN MOTOR KW	7.5	
FACING HEAD	MAX. FACING HEAD TORQUE N.M	1960	
	FACING HEAD DIAMETER (mm)	600	
	RANGE OF FACING HEAD SPEED R/MIN	4-200	
	NUMBER OF FACING HEAD SPEED	18	
TABLE	TABLE WORKING SURFACE (L×W) (mm)	1100×960	
	MAX. PERMISSIBLE LOAD ON TABLE (kg)	2500	
	T-SLOT (mm)	22	
	NUMBER OF T-SLOT	7	
WORKING RANGE	X-AXIS TRAVEL (mm)	900	
	Y-AXIS TRAVEL (mm)	900	
	Z-AXIS TRAVEL (mm)	1400	
	W-AXIS TRAVEL (SPINDLE TRAVEL) (mm)	600	
	U-AXIS TRAVEL (FACING SLIDE) (mm)	180	
	B-AXIS WORKTABLE ROTARY	360 °	
	DISTANCE BETWEEN SPINDLE AXIS & TABLE SURFACE (mm)	0	
FEED RANGE OF	RAPID TRAVEL (X/Y/Z/W) (mm/min)	2500	
REVOLUTION	RANGE OF AXES SPEED PER SPINDLE REV.(X/Y/Z/W)	0.04-6/0.01-1.88	
PRECISION	MEASUREMENT SYSTEM READING PRECISION (X/Y/Z) [Z-AXES MEASUREMENT		
	OPTIONAL] (mm)	0.005	
	B-AXIS MEASUREMENT SYSTEM READING PRECISION [B-AXIS MEASUREMENT		
	OPTIONAL]	0.001 °	
GENERAL	OVERALL DIMENSIONS (L×W×H) MM	4910×2454×2750	
	PARAMETERS	WEIGHT OF MACHINE (kg)	13000
		CNC CONTROLLER	211MB

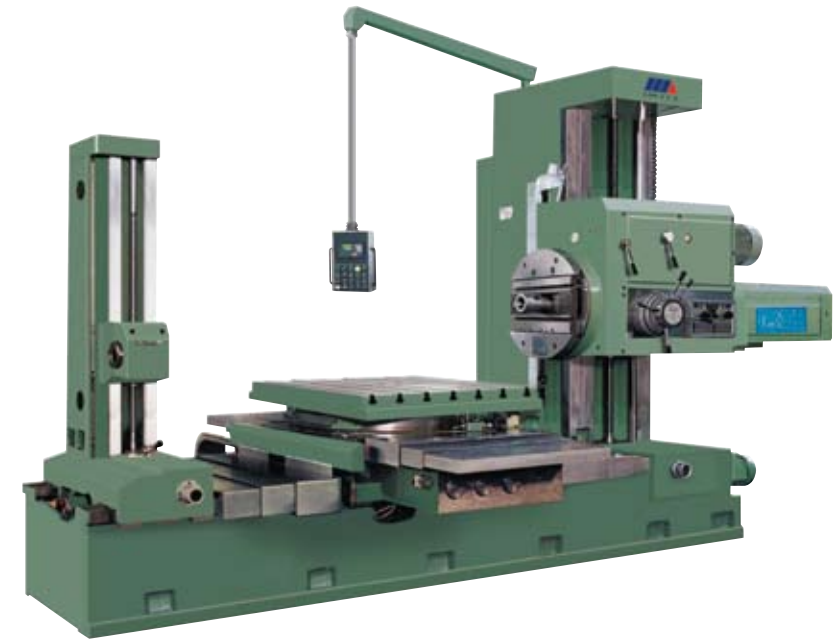

SMTCL TPX611B

SMTCL precision machine tools are designed with many innovative features that provide outstanding performance, reliability, and productivity to our customers. These are utilized in a wide variety of industries, such as automobile, national defense and military, aerospace and aviation, railway transportation, and so on. Some of the uses of our products include: conventional lathes, used for turning internal, external and cylindrical surfaces; flat bed CNC lathes, primarily used in machining surfaces of axes and discs, tapered surfaces, arc surfaces, threads and boring holes; milling boring machining centers designed for processing medium to large sized workpieces of various materials; pipe threading lathes ideally suited for machining Metric and Whitworth threads as well as taper threads.

SMTCL - Z3040 x 12/1

VARIABLE FREQUENCY MOTOR, HYDRAULIC PRIMARY MECHANISM

REALIZES STEPLESS SPEED REGULATION

FORWARD AND REVERSAL STALL WITH ONE HANDLE

CENTRALIZED OPERATION

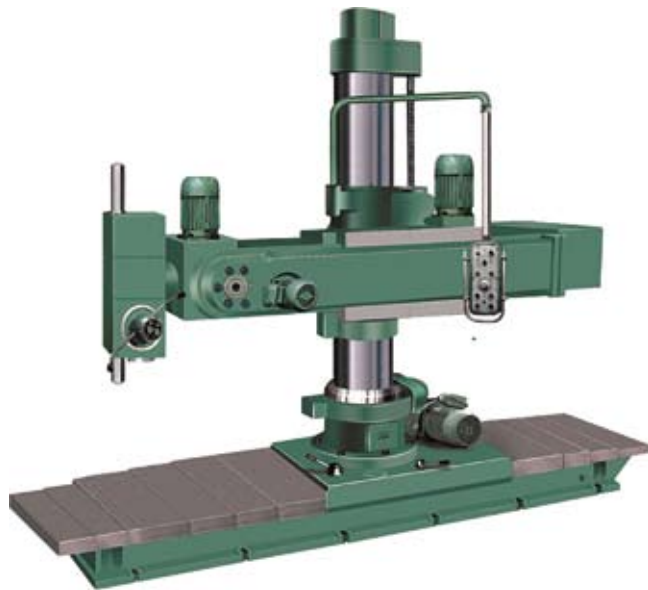

MODEL	Z3040 x 12/1	
MAX DRILL DIAMETER (mm)		40
DISTANCE BETWEEN SPINDLE & COLUMN (mm)	MAX	1250
	MIN	350
DISTANCE SPINDLE NOSE & WORKING SURFACE (mm)	MAX	1250
	MIN	350
SPINDLE TRAVEL		315
RPM		25-2000
NUMBER OF SPINDLE SPEEDS		16
POWER MAIN MOTOR (kW)		3
OVERALL SIZE (mm)		2150 x 1070 x 2840

SMTCL Z SERIES

SMTL - CAK63 series

This series of CNC lathes have horizontal flat-vee hardened guide-ways, with the undersides of slides coated with TSF anti-friction material, for flexible operation and stable and reliable accuracy.

MODEL	CAK63		
MAX. SWING DIAMETER OVER BED (mm)	630		
SPAN OF GUIDEWAY (mm)	550		
MAX. WORKPIECE LENGTH (mm)	750 1000 1500 2000 3000		
MAX. CUTTING LENGTH (mm)	600 850 1350 1850 2850 [VERTICAL 4-POS.]		
	450 700 1200 1700 2700 [HORIZONTAL 6-POS.]		
MAX. CUTTING DIAMETER VERTICAL TURRET (mm)	630		
MAX. SWING DIAMETER OVER SLIDE VERTICAL (mm)	350		
MAX. CUTTING DIAMETER HORIZONTAL TURRET (mm)	500 (HORIZONTAL 6-POSITION)		
	410 (HORIZONTAL 8-POSITION)		
MAX. CUTTING DIAMETER OVER SLIDE (mm)	350 (HORIZONTAL 6-POSITION)		
	310 (HORIZONTAL 8-POSITION)		
SPINDLE NOSE	D11		
CHUCK (mm)	MANUAL 325	HYDRAULIC 12	
INNER TAPER OF SPINDLE NOSE	1:20		
SPINDLE BORE DIAMETER (mm)	104		
SPINDLE SPEED VARIABLE FREQUENCY MOTOR (N)	AUTO 4-GEARSHIFT, STEPLESS		
RANGE OF SPINDLE SPEED			
VARIABLE FREQUENCY MOTOR (rpm)	17-128; 38-278; 75-570; 170-1000		
MAIN MOTOR POWER VARIABLE FREQUENCY MOTOR	11 (kW)		
CENTER HEIGHT DISTANCE FROM BED (mm)	315		
DISTANCE FROM GROUND (mm)	1110		
X/Z AXIS RAPID SPEED (m/min)	4/8		
INDEX TIME OF TURRET (1 POSITION) (S)	3.9 (VERTICAL 4-POSITION) 3.6 (VERTICAL 6-POSITION) 1.7 (HORIZONTAL 6-POSITION) 1.6 (HORIZONTAL 8-POSITION)		
REPEATABILITY OF TURRET INDEX (S)	±2		
X AXIS TRAVEL (mm)	320		
Z AXIS TRAVEL (mm)	600/850/1350/1850/2850		
ACCURACY OF WORKPIECE	IT7		
SURFACE ROUGHNESS OF WORKPIECE (μM)	RA1.6		
DIAMETER/TRAVEL OF TAILSTOCK SLEEVE (mm)	100/250		
BORE TAPER OF TAILSTOCK (mm)	MORSE 5#		
SIZE OF TOOL SHANK EX. CIRCLE TOOL (mm)	32×32	BORING TOOL	32
STEADY REST (mm)	20 - 170 (2M/3M) 80 - 250		
TOTAL CAPACITY OF POWER SUPPLY (KVA)	30		
MACHINE WEIGHT (NET/GROSS) (kg)	3900/4550 [CAK6360] kg		
PACKING DIMENSIONS (L×W×H) (mm)	3040×2070×2310 [CAK6360]		



SMTCL CAK63 SERIES

CAK 63/80 series CNC lathes integrate proven structure, stable functionality, and reliable quality to make an economical, practical, universal machine. They are widely used in such industries as automotive, petroleum, military, among others. They are the preferred lathe among customers in China.

This series of machine tools can be used in a wide range of applications, and can machine inside or outside surfaces of shaft-type work-pieces and disc-type workpieces, curved surfaces, arcs, threads, bores, and reaming holes, among other things. Various CNC systems and accessories can be provided according to the needs of the customer.

SMTCL - CAK3665

This series of machine tools can be used in a wide range of applications, and can machine inside or outside surfaces of shaft-type work-pieces and disc-type workpieces, curved surfaces, arcs, threads, bores, and reaming holes, among other things. Various CNC systems and accessories can be provided according to the needs of the customer.



SMTCL CAK3665 SERIES

CNC Heavy Duty Precision Lathe is a very popular product line in metal industry. The spindle motor power in the series is transmitted to the spindle through pulley, belt and 4-step gear sets. It could perform heavy duty machining with high speed and high rigidity.

MODEL	CAK3665
MAX. SWING DIAMETER OVER BED (mm)	360
MAX. SWING DIAMETER OVER SLIDE (mm)	180
MAX. CUTTING DIAMETER OVER SLIDE (mm)	180
MAX. CUTTING DIAMETER (mm)	360 (VERTICAL 4-POSITION) 320 (HORIZONTAL 6-POSITION)
MAX. TURNING LENGTH (mm)	650 (VERTICAL 4-POSITION) 550 (HORIZONTAL 6-POSITION)
DIAMETER OF SPINDLE BORE (mm)	53
SPINDLE NOSE	A6
MAIN MOTOR POWER (FREQUENCY-CHANGE) (kW)	5.5
SPINDLE SPEED (N)	STEPLESS
SPINDLE SPEED RANGE	MANUAL CHUCK 200-2000 (rpm) HYDRAULIC CHUCK 200-3000 (rpm)
DIAMETER OF TAILSTOCK SLEEVE (mm)	60
TRAVEL OF TAILSTOCK SLEEVE (mm)	140
TAPER BORE OF TAILSTOCK SLEEVE	MORSE 4#
X AXIS TRAVEL (mm)	220
Z AXIS TRAVEL (mm)	650
X/Z AXIS RAPID SPEED (m/min)	6/10
SIZE OF TOOL SHANK EX. CIRCLE TOOL (mm)	20×20
BORING TOOL (mm)	32
X/Z AXIS REPEATABILITY	0.012/0.016
MACHINING ACCURACY	IT6-IT7
STEADY REST (mm)	30-80
TOTAL CAPACITY OF POWER SUPPLY (KVA)	15
EXTERNAL DIMENSIONS OF MACHINE (L×W×H) (mm)	2220×1400×1600
NET/GROSS WEIGHT OF MACHINE (kg)	1860/2110
PACKING DIMENSIONS (L×W×H) (mm)	2520×1660×2050

Vertex Products

BDMS offer the whole Vertex machine tools accessories product range, including:

- Milling Machine accessories
- Grinding machine accessories
- Tooling systems
- Machining centre accessories
- Lathe accessories

**CONTACT US FOR A VERTEX CATALOGUE
OVER 2000 ITEMS LISTED**



Vertex Chuck

4 Jaw Independent Chuck 100mm to 800mm



Vertex Chuck

3 Jaw Scroll Chuck 85mm to 405mm



Vertex Chuck

Collet Chucks



Vertex Chuck

Hydraulic Power chucks 135mm to 381mm



Vertex Tooling

HSK Tooling



Vertex Tooling

Drill Chucks



Vertex Tooling

BT Milling Holders



Vertex Tooling

Multi Lock Milling Chucks



Vertex Tooling

High Precision Boring Head Set

Vertex Accessories

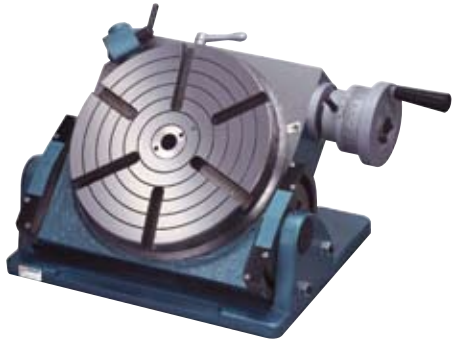

Vertex Accessories

Universal Tilting Rotary Table



Vertex Accessories

Tool Holder Stands



Vertex Accessories

Electronic Edge Finders



Vertex Accessories

Angle Plates



Vertex Accessories

Tool Height Setters



Vertex Accessories

Tool Height Setters



Vertex Accessories

Magnetic Chucks

Vertex Work holding



Vertex Work Holding

Precision Pneumatic Power Vise



Vertex Work Holding

Universal Hydraulic Machine Vise



Vertex Work Holding

Power Vise



Vertex Work Holding

Double Clamp Vise



Vertex Work Holding

Upright MC Power Vise

GSA Products

BDMS offer the whole GSA Range of products including:

- CNC Rotary Tables
- 5 axis Trunnion tables
- Tailstocks
- Table Controllers

CONTACT US FOR A GSA CATALOGUE



GSA Rotary Table

CNC-400R – CNC -800R Vertical / Horizontal Rotary Table



GSA Multi Spindle

CNC-200RW Vertical / Horizontal Multi Spindle Rotary Table



GSA Horizontal Rotary / Index Table

HIT-400-HIT-800 Horizontal Rotary Table



GSA Rotary Table

CNC-120R – CNC -320R Vertical / Horizontal Rotary Table



GSA Accessories

CNC-1000HV-CNC2000HV Large Rotary Table



GSA Accessories

M-Mate M Code Controller for conventional machines



GSA Tilting Rotary Table

CNCT-320 – CNCT-800 Tilting Rotary Table



GSA Accessories

G-Mate Servo Controller



GSA Accessories

TSA-320S – Strong Tailstock



GSA Trunnion Table

CNCT-320SW-CNCT-800SW 5 axis Trunnion Table

RMTS

RAPID MACHINE TOOL SERVICES

Breakdown repairs

Installation

Levelling

Rebuilding

Machine alignment checks and adjustments

Retrofit

Parts sourcing and supply

Scheduled servicing

YOUR QUALITY INDEPENDENT CHOICE

Trusted Supplier at Reasonable Rates

Factory Trained, Licensed & Insured for your peace of mind

Let Our Decades of Experience Save You Money

We provide services that include:

- Mazak/Mitsubishi & Fanuc
- Electrical Breakdown Repair
- Mechanical Realignments
- Mechanical Breakdown Repair
- Re-leveling & Commissioning After Relocation
- Electronic Repairs to Component Level
- All Repairs to all Makes
- Regular Scheduled Servicing

www.rmts.com.au

Your one stop shop for all repairs

ONE CALL DOES IT ALL



0417 778 036

Commercial Finance Specialist

Are you seeking commercial finance? Having the right loan structure in place and making the right presentation to the banks when seeking commercial finance can make all the difference.

Deal with a professional who has over 25 years commercial finance experience who is devoted to presenting a high-quality application to lenders to give you the edge on getting your loan approved.

Whether you are a supplier of manufacturing equipment wanting to help your customers with asset finance, or a purchaser of business equipment looking for competitive business finance talk to Smartline's Shane Swinton to find the right product for you.

- Machinery and equipment finance
- Commercial property
- Business working capital
- Home loans
- Investment property loans



Call Shane Swinton today on 0409 004 925 or email sswinton@smartline.com.au

**16 Stirling St, Thebarton SA 5031
www.smartline.com.au/sswinton**

Australian Credit Licence Number 385325



Testimonial

Stewart Eason has worked with Shane Swinton of Smartline Personal Mortgage Advisers for five years.

In that time, Shane has arranged all of Stewart's finance – from his home and vehicle finance through to business overdrafts.

Stewart appreciates Shane's honesty, and his plain-speaking and straightforward approach.

In addition to Shane's lending and finance expertise, given the nature of Stewart's business, it's his in-depth understanding of the engineering and manufacturing sector that most impresses him.

"He understands the terminology and the technical jargon, and he has a good knowledge of the industry's requirements and unique economic climate" Stewart says.

"He's extremely reliable, and his professionalism and client service is outstanding. That's why I happily refer all of my clients, friends and family to Shane if they're looking for assistance with any of their finance needs."

I can't sing his praises highly enough."

Stewart Eason

June 2012

Personal and Business client for 5 years

14 Kitawah Street
Lonsdale, South Australia 5160

Mobile: +61 423923453
Phone: +61 8 8186 6333
Fax: + 61 8 8186 6322
Email: sales@bdms.com.au

www.bdms.com.au

