

SPECIFICATION:

Model	DV-14 series				DV-17 series			DV-19 series			DV-21 series		
	1417	1422	1432	1442	1722	1732	1742	1922	1932	1942	2122	2132	2142
TRAVEL													
TRAVEL RANGES (X x Y x Z mm)	1700x1400x900	2200x1400x900	3200x1400x900	4200x1400x900	2200x1700x900	3200x1700x900	4200x1700x900	2200x1900x900	3200x1900x900	4200x1900x900	2200x2100x900	3200x2100x900	4200x2100x900
SPINDLE NOSE TO TABLE SURFACE (mm)	160-1060				160-1060			160-1060			160-1060		
SPINDLE CENTER TO COLUMN (mm)	404				404			404			404		
DISTANCE BETWEEN COLUMN (mm)	1400				1900			1900			2100		
TABLE													
TABLE SIZE (mm)	1700x1200	2200x1200	3200x1200	4200x1200	2200x1500	3200x1500	4200x1500	2200x1700	3200x1700	4200x1700	2200x1700	3200x1700	4200x1700
T-SLOT (Width x Distance x Number mm)	22x150x7				22x150x9			22x150x11			22x150x11		
MAX. TABLE LOAD (Kgs)	5000	5000	8000	8000	8000	10000	12000	8000	10000	12000	8000	10000	12000
SPINDLE													
TOOL SHANK & PULL STUD	ISO50				ISO50			ISO50			ISO50		
SPINDLE INNER DIAMETER (mm)	Ø100				Ø100			Ø100			Ø100		
SPINDLE SPEED (rpm) Gear	8000				8000			8000			8000		
DRAW BAR FORCE (Kgf)	1800				1800			1800			1800		
MAIN MOTOR (con/30min kW)	15/18.5				15/18.5			15/18.5			15/18.5		
AXIS SERVO MOTOR													
RAPID FEED RATE (X/Y/Z m/min)	20/20/20	16/20/20	16/20/20	12/20/20	16/16/20	16/16/20	12/16/20	12/16/20	12/16/20	10/16/20	12/16/20	12/16/20	10/16/20
FEED RATE (X/Y/Z mm/min)	10000				10000			10000			10000		
MITSUBISHI kW	HF703 7.0				HF703 7.0			HF703 7.0			HF703 7.0		
FANUC kW	α 30/3000i 7.0				α 30/3000i 7.0			α 30/3000i 7.0			α 30/3000i 7.0		
SIEMENS kW	1FK7 103 7.0				1FK7 103 7.0			1FK7 103 7.0			1FK7 103 7.0		
FAGOR kW	FXM75.20 7.0				FXM75.20 7.0			FXM75.20 7.0			FXM75.20 7.0		
HEIDENHAIN kW	QSY190D 9.6				QSY190D 9.6			QSY190D 9.6			QSY190D 9.6		
AUTO TOOL CHANGER													
ATC TYPE	DISK/CHAIN				DISK/CHAIN			DISK/CHAIN			DISK/CHAIN		
CAM TYPE	ARM				ARM			ARM			ARM		
TOOL SELECTION (Bi-direction)	RANDOM				RANDOM			RANDOM			RANDOM		
TOOL STORAGE CAPACITY (PCs)	24/32				24/32			24/32			24/32		
MAX. TOOL DIAMETER (mm)	Ø115/Ø127 (Ø160/Ø250)				Ø115/Ø127 (Ø160/Ø250)			Ø115/Ø127 (Ø160/Ø250)			Ø115/Ø127 (Ø160/Ø250)		
MAX. TOOL LENGTH (mm)	350				350			350			350		
MAX. TOOL WEIGHT (Kg)	20				20			20			20		
MISCELLANEOUS													
AIR REQUIREMENT (Kg/cm ²)	6				6			6			6		
HYDRAULIC REQUIREMENT(kg/cm ² ,L)	60,40L				60,40L			60,40L			60,40L		
VOLTAGE	220				220			220			220		
POWER REQUIREMENT (KVA)	50				50			50			50		
COOLANT TANK CAPACITY (L)	900				900			900			900		
MACHINE WEIGHT (KGS)	15500	16000	17000	18000	21000	22500	24000	22000	23500	25000	23500	24000	25500
MACHINE HEIGHT (mm)	4500				4500			4500			4500		
FLOOR SPACE (L x W mm)	5800x4150	6090x4150	8130x4150	10310x4150	6090x5300	8130x5300	10310x5300	6090x5300	8130x5300	10310x5300	6090x5300	8130x5300	10310x5300

Standard Accessories:

Air blast through spindle
Air blast for workpiece (nose)
Automatic lubrication system
Working lamp
Operation status light
Screw type chip conveyors
Chain type 32-tool ATC
Gear head

Cooling System
Z axis pneumatic balance system
Air gun/water gun
MPG handwheel
Heat exchanger
RS-232 Interface
Rigid tapping
Spindle oil cooler
Tool box

Leveling bolts and pads
Operation and programming manual
Semi-full splash safety guard

Options:

Z-travel: 1100mm
Extend column: 300mm
Full Splash Guard
Coolant through Spindle
Linear Scales
Auto tool length measurement
Auto workpiece measurement
Manual Universal Head (90 Degree)
Auto Universal Head (90 Degree)
Rotary table
Adjusting tools and box
Foundation bolt

Pinnacle Machine Tool Co., Ltd.



No.35, Alley. 15, Lane. 330, Shenzhou Rd.,
Shengang Dist., Taichung City 42949, Taiwan
TEL:886-4-25252995
FAX:886-4-25252991
E-mail:info@pinnacle-mc.com
http://www.pinnacle-mc.com

DOUBLE COLUMN MACHINING CENTER

Pinnacle

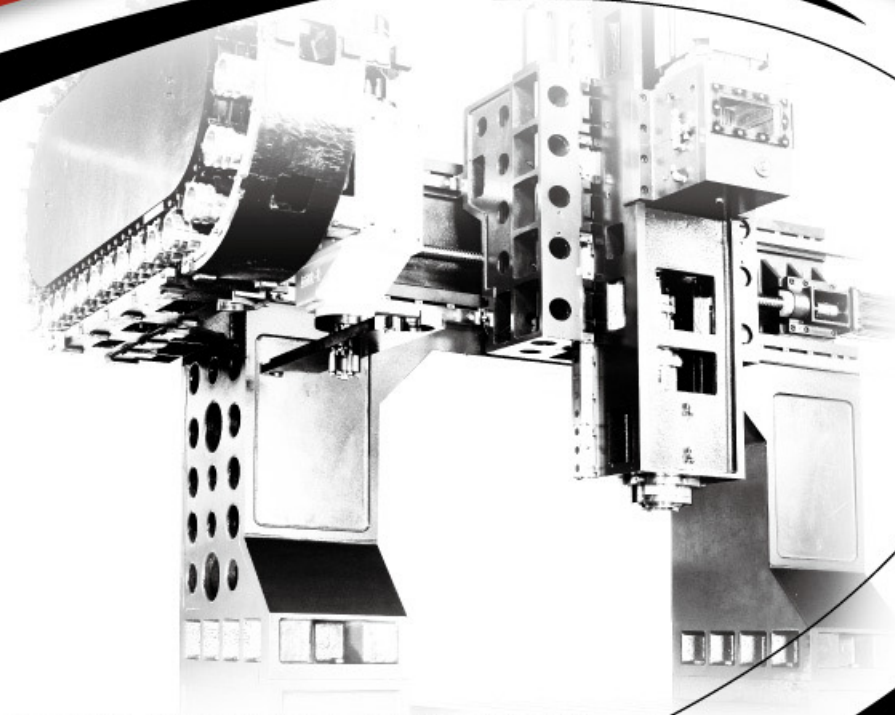

A Dependable Source for Outstanding Machinery to Compliment Your Workforce

DOUBLE COLUMN MACHINING CENTER

DV14

DV17 / DV19 / DV21

FEATURES

1. PERFECT STRUCTURE DESIGN: Rugged construction throughout guarantees superior rigidity and stability.
2. The five major structural parts are all manufactured from high quality Meehanite cast iron (FC30) and ductile iron (FCD500), hardened to hardness of over HB190. The structural parts are also tempered to relieve stress.
3. Three axes slideways are mounted with roller type linear ways, enabling each axis movement to achieve highest rigidity, increased loading capacity and higher dynamic stability. This also results in greater machining accuracy, high accuracy and longer tool life. The slide blocks for table are mounted every 500mm to ensure uniform load distribution.
4. Three axes are transmitted by class C3 precision ball screws which are preloaded and pretensioned, effectively improving rotating rigidity of nuts while minimizing thermal deformation of ball screws due to heat growth.
5. BT50, 8,000RPM direct-drive spindle combined with high/low speed gearbox meets the requirements of high speed, high precision and high torque output at low speed. Also, available to equip with coolant through spindle for efficient cooling on workpiece and tool in heavy cutting. This also results in longer tool life and higher parts accuracy.
7. The spindle head on Z-axis employs an automatic compensated balance system (SCBS) to improve upon the problem of defects found on conventional counter-balance weight and hydraulic systems. This special system does not require additional power unit. It employs an accumulator to control hydraulic cylinder, combined with servomotor driving the spindle head. With this special balance system, high speed and high precision machining are obtainable. Servomotor load is reduced. The spindle head does not slip even in the event of power failure, ensuring safety protection for tool and workpiece.
8. Automatic lubrication system delivers oil with automatic metering and timing. It accurately delivers oil to each linear way and ball screw.
9. The base and the column are box type, one-piece construction combined with solid support for maximum stability when loading extra large workpiece.
10. DV14 Series The beam and the columns are one-piece constructed to minimize beam deformation while upgrading rigidity.
11. The slide is a ladder type construction for increasing mating surfaces, reducing beam deformation to a minimum and significantly improving rigidity.
12. The spindle head is a symmetrical layout with box type construction. Shortened distance between spindle center and Z-axis slideway faces. The spindle head operates together with a gearbox to fully exhibit extra heavy cutting capability.
13. Lubrication oil on 3 axes and coolant are separately collected. This feature will extend coolant life and meets environmental requirements.



• Full Splash Guard (Option)

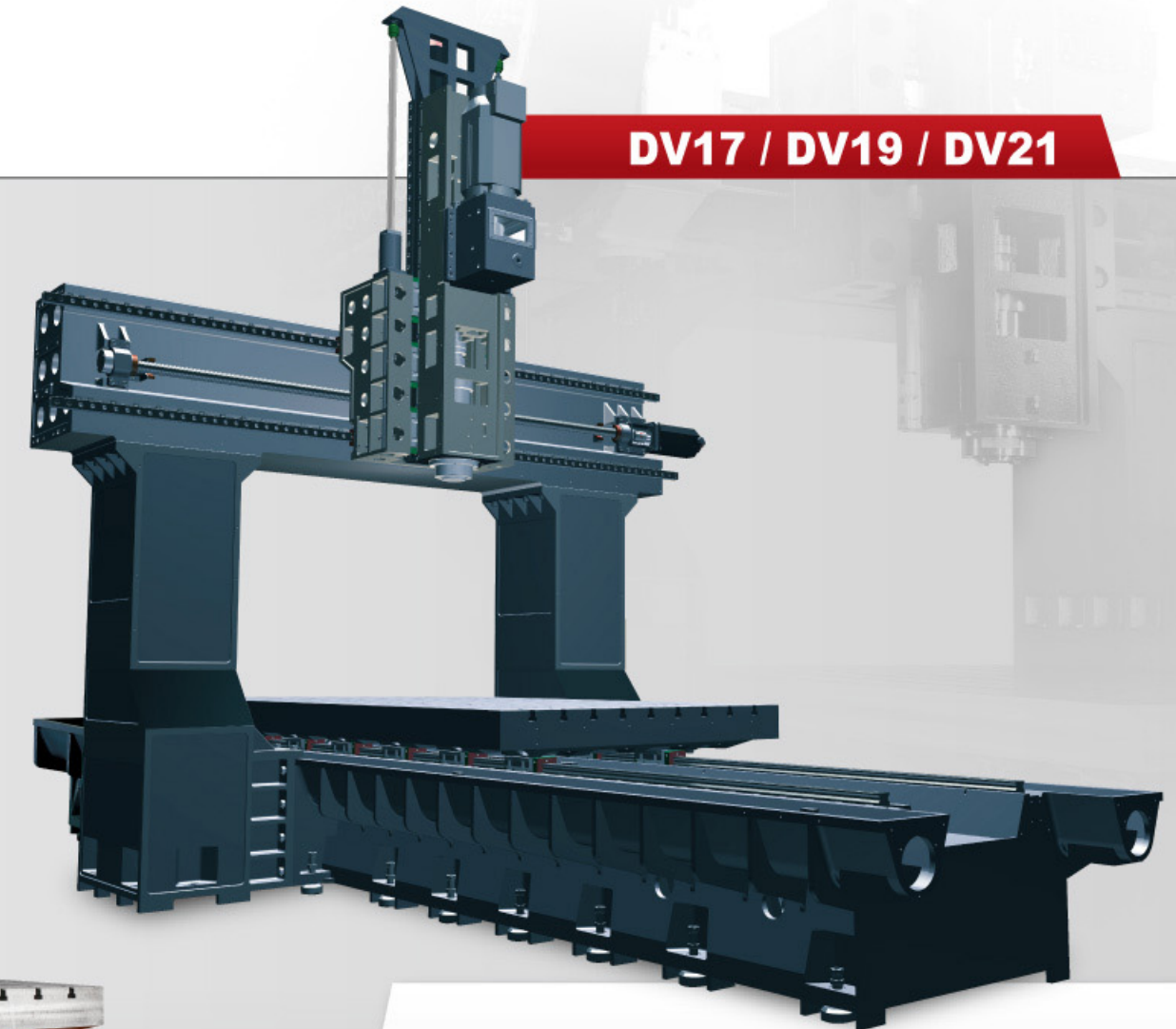
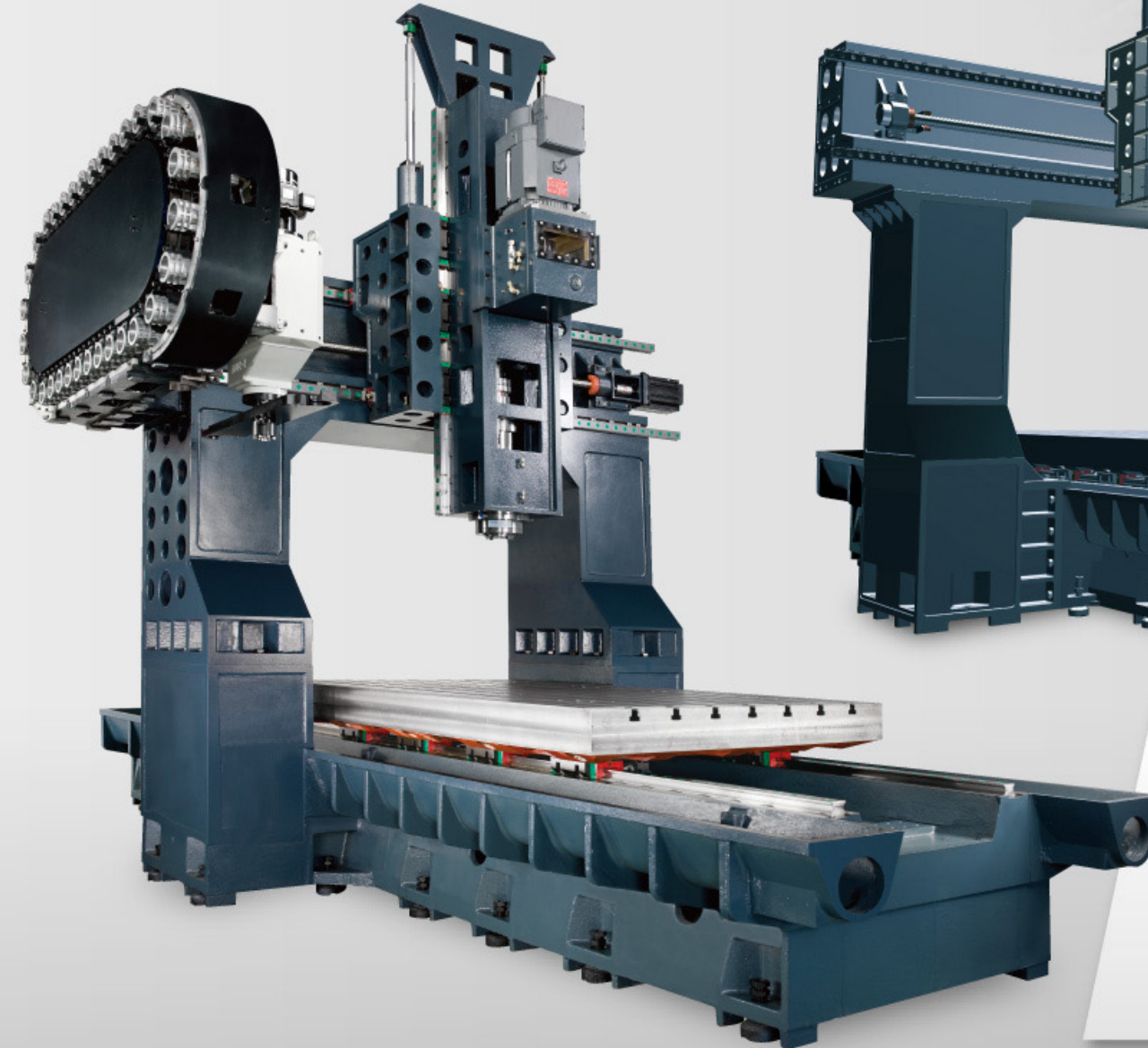

- All major structural parts are manufactured from high quality cast iron with tempering treated to relieve stress, ensuring maximum material stability without deformation.
- Box type structural parts are rib reinforced to increase structural strength and rigidity.
- Extra heavy base complete support of table and resists heavy load without deformation.
- X, Y, Z axis are mounted with roller type linear ways combined with extra wide between ways for added stability.

Perpendicular linear guide way arrangement.
High damping coefficient, especially in Axial and Radial direction.

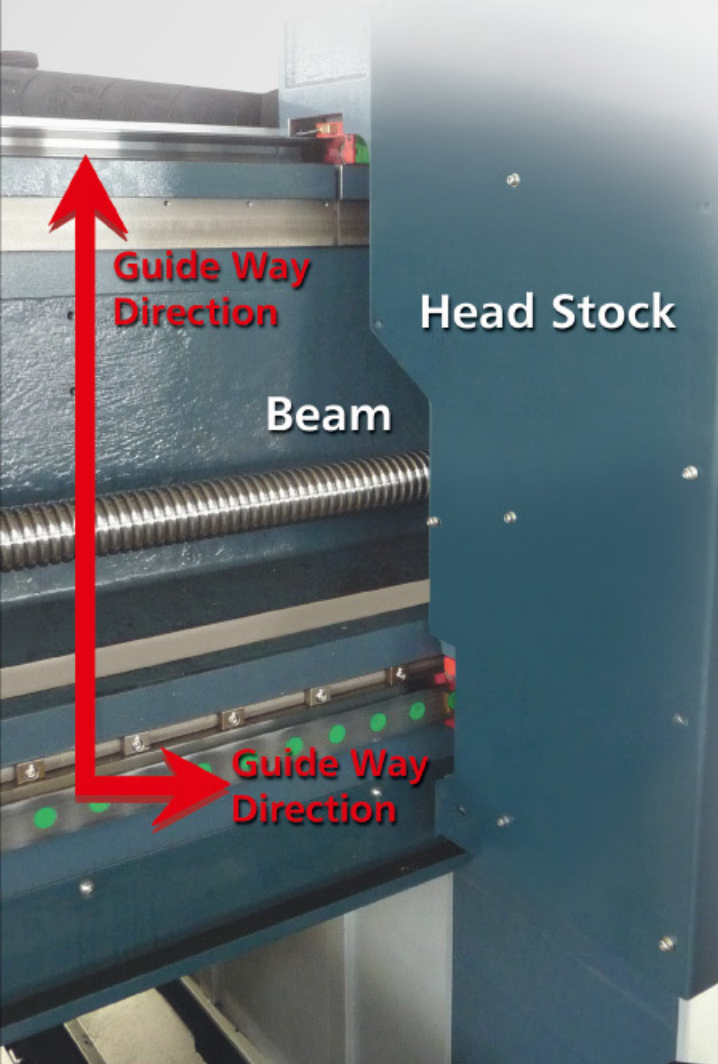

RIGID SPINDLE HEAD

- The spindle head is a box-type construction that increases stability when performing heavy loading.
- The linear ways on Z axis are specially designed with side layout to upgrade rigidity of the spindle head.

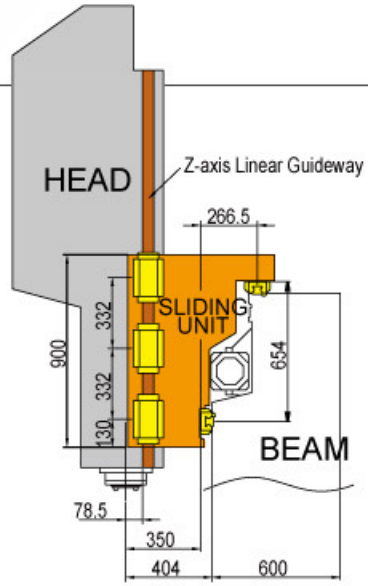

GEAR HEAD

- The spindle running is transmitted through a gear box, making the machine excellent for heavy cutting applications.
- Wide spindle speed range from 10 to 6,000 rpm permit the machine to perform heavy cutting and fine finishing.
- All gears and bearings in the gear box are oil-bath lubricated.

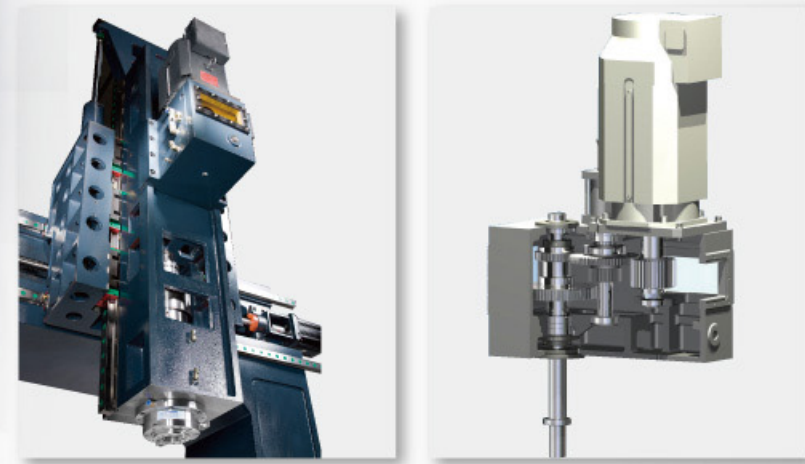

SPINDLE



32 TOOLS CHAIN TYPE MAGAZINE (STANDARD)

- The magazine is driven by a precision cam, featuring fast and accurate tool positioning.
- Tool selection is bi-directional and random for fast tool change.
- The magazine accepts ISO 50 tool shank.
- The magazine is separately mounted from the cutting area combined with a protection door to prevent tools contamination from chips or coolant.

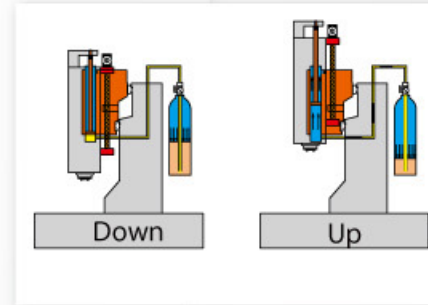

PNEUMATIC BALANCE ON Z-AXIS

The Z-axis movement is counter-balanced through a pneumatic counter-balance system. An accumulator is equipped in the air circuit, ensuring fast and stable movement of Z-axis.



NITROGEN CANISTER

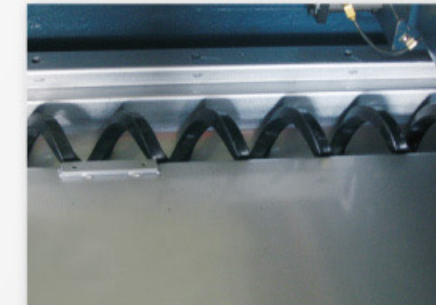

TWO SCREW TYPE CHIP CONVEYORS ON BASE

There are two screw type chip conveyors provided at right and left side of the base. During cutting, the chips are delivered through these chip augers to a chip conveyor for exhausting chips outside the machine.



CHAIN TYPE CHIP CONVEYOR

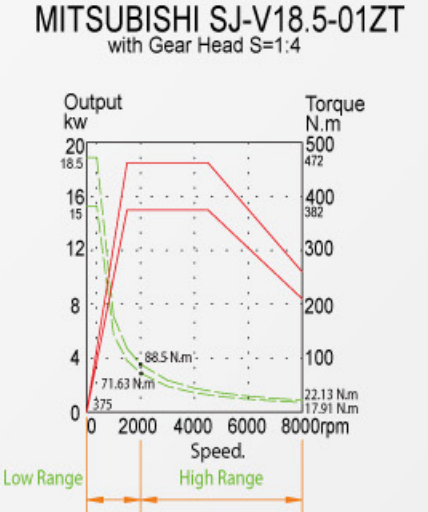
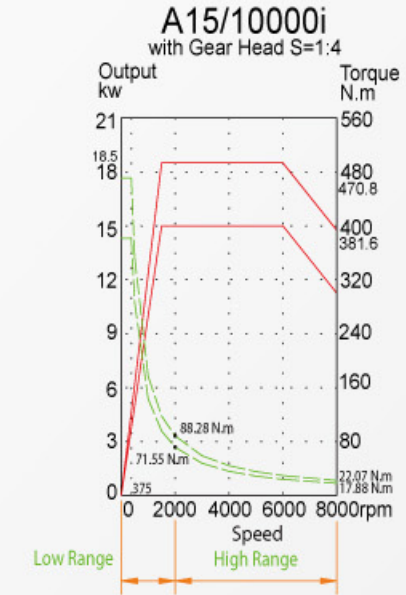

OPTIONAL ▶



Manual 90° Milling Head



Automatic 90° Milling Head



Manual Universal Milling Head



Straight Extension Head



90° Boring Milling Head



90° MILLING HEAD

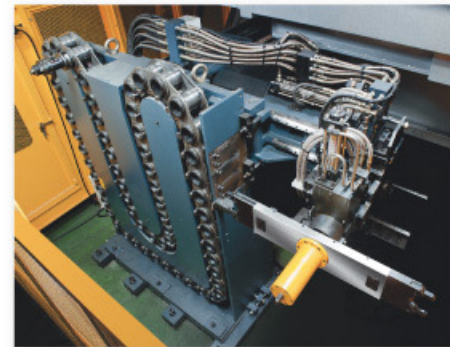

VERTICAL / HORIZONTAL / ATC



LASER INSPECTION



BALL BAR INSPECTION

ACCURACY

Each Pinnacle machine is subject to dynamic and static accuracy tests. Pinnacle machine accuracy meets ISO 10791 VDI 3441, ISO 230, JIS B6388 and ASMEB5 standards.

Standard	ISO 10791-4		Pinnacle
	Axis Travel >1250mm<2000mm		
Tolerances			
Bi-directional Positioning	A:	0.042	0.008mm
Bi-directional Repeatability	R:	0.020	0.008mm
JIS B6336-4 shows the same value as ISO Standard: P value of VDI / DGQ3441 is equivalent to A of ISO10791-4, and PS is equivalent to R All values shown above are measured for machine in good air conditioned environments.			

WORK RANGE / TABLE SIZE

DV14

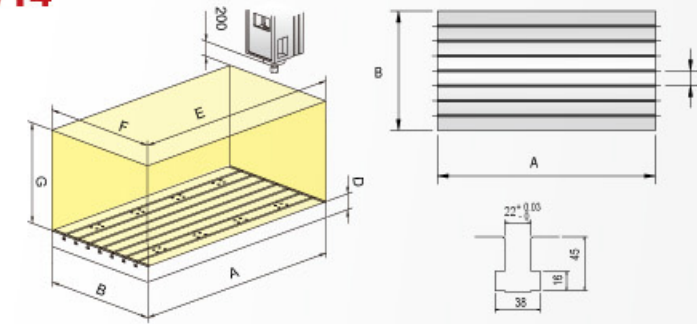

DV17 / DV19 / DV21

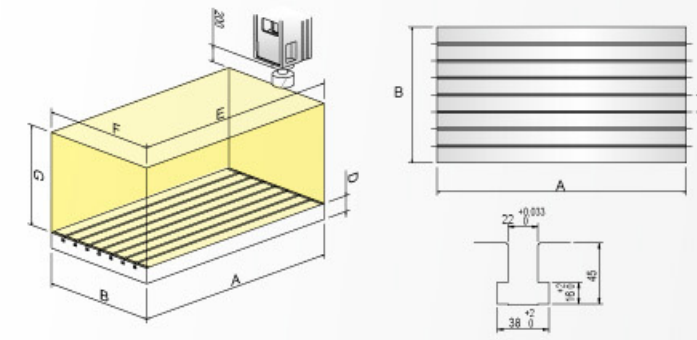

	A	B	C	D	E	F	G
DV1417	1700	1200	150	150	1700	1200	900
DV1422	2200	1200	150	150	2200	1200	900
DV1432	3200	1200	150	150	3200	1200	900
DV1442	4200	1200	150	150	4200	1200	900
DV1722	2200	1500	150	150	2200	1500	900
DV1732	3200	1500	150	150	3200	1500	900
DV1742	4200	1500	150	150	4200	1500	900
DV1922	2200	1700	150	150	2200	1700	900
DV1932	3200	1700	150	150	3200	1700	900
DV1942	4200	1700	150	150	4200	1700	900
DV2122	2200	1700	150	150	2200	1700	900
DV2132	3200	1700	150	150	3200	1700	900
DV2142	4200	1700	150	150	4200	1700	900

FLOOR SPACE

DV14

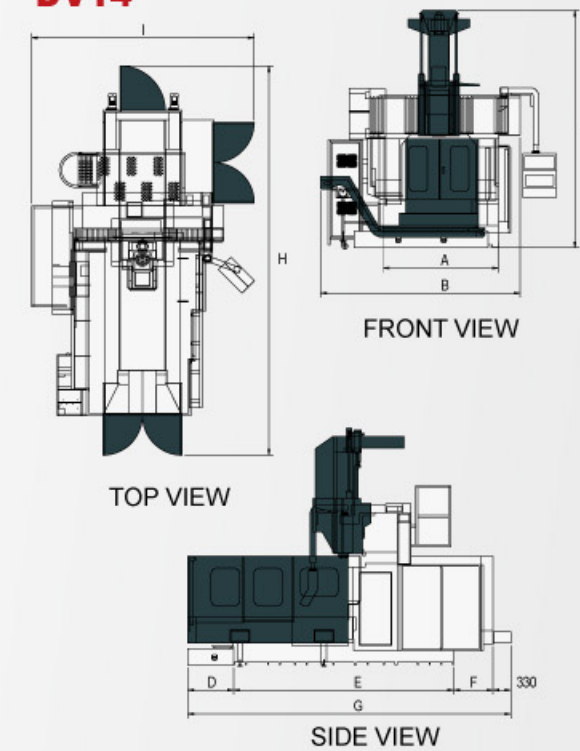

DV17 / DV19 / DV21

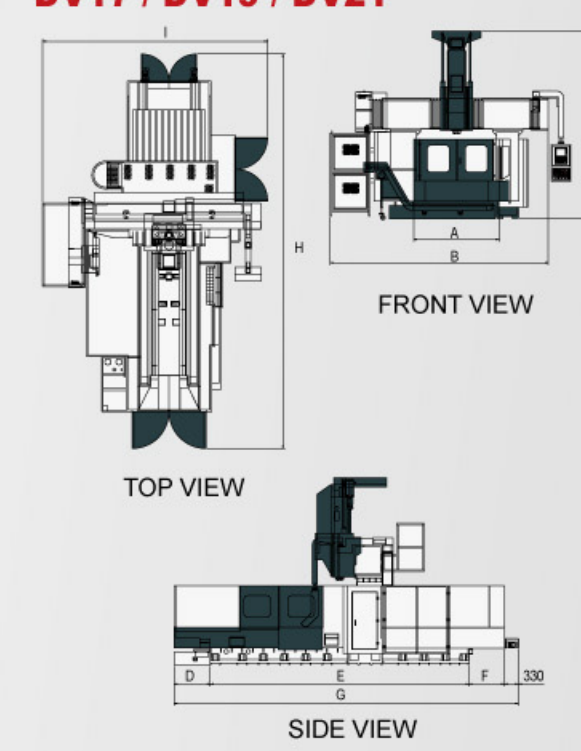

	A	B	C	D	E	F	G	H	I
DV1417	2150	3720	4420	710	4100	660	5800	7025	4150
DV1422	2150	3720	4420	860	4100	735	6025	7250	4150
DV1432	2150	3720	4420	860	6100	840	8130	9355	4150
DV1442	2150	3720	4420	950	8100	930	10310	11535	4150
DV1722	2225	5150	4420	840	4100	820	6090	7260	5310
DV1732	2225	5150	4420	860	6100	840	8130	9300	5310
DV1742	2225	5150	4420	950	8100	930	10310	11480	5310
DV1922	2225	5150	4420	840	4100	820	6090	7260	5310
DV1932	2225	5150	4420	860	6100	840	8130	9300	5310
DV1942	2225	5150	4420	950	8100	930	10310	11480	5310
DV2122	2875	5150	4420	840	4100	820	6090	7660	5310
DV2132	2875	5150	4420	860	6100	840	8130	9700	5310
DV2142	2875	5150	4420	950	8100	930	10310	11880	5310