

Pinnacle
Since 1976



Pinnacle Machine Tool Co., Ltd.

No. 149, Sec. 1, Goufeng Rd., Shengang Dist.,
Taichung City 42949, Taiwan
TEL:886-4-25252995
FAX:886-4-25252991
E-mail:info@pinnacle-mc.com
http://www.pinnacle-mc.com



High-Tech Expertise in
5-axis machining
Strategies for success in cutting
edge technology

2017_08.1000-1





Pinnacle

"exceeds your expectation"

WIDE PRODUCT RANGE

Pinnacle Machine Tool Co., Ltd. was founded in 1976. With excellent experience in **Technology, Quality & Service**. We are specialized in manufacturing all kinds of machining centers such as 5-axis, double column, vertical, and horizontal. Furthermore, we have a wide range of CNC lathes as well. The complete product lines with outstanding quality satisfy the needs of our valuable customers worldwide.

STRONG TECHNICAL SUPPORT & AFTER SERVICE

R&D is teamed up by experienced engineers with decades of expertise in machine tool industry. By means of applying up-to-date technologies such as CAD/CAM/CAE software and Finite Element Analysis, our machines are robustly constructed, assuring optimum rigidity and stability. Our reliable partnerships with dealers keep us connected closely with the latest technologies and market trends, hence ensuring Pinnacle product developments are upgraded constantly.

Well-trained service engineers are familiar with each step of assembly to ensure our quality service works and keep all machines running in the best status. Training courses to service engineers are held periodically to keep the team refreshed with the latest technology and skills.

Pinnacle's reputation is built on quality, it relies on an excellent quality control system and systematic management. The in-coming parts are inspected under the highest standard by using precision equipment during production, assembly and final test run processes.

The sales and service departments provide customers pre-sale and after-sale services. Prompt reaction is just our basic attitude to all customers only, accurate and effective technical solutions are provided within the shortest time.



High-Tech Expertise in 5-axis Rotary Table

- Rotary Table diameter Ø320/Ø450mm
- Table rotation and tilting are driven by servo motor
- Positioning accuracy, A/C-axis: 15" / 10"
- Repeatability accuracy, A/C-axis: 10" / 8"

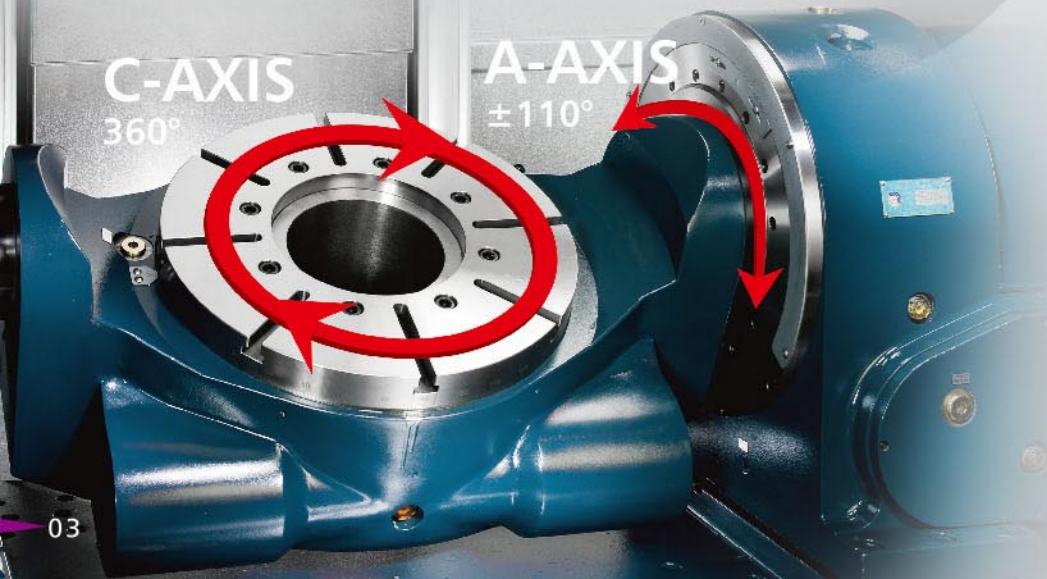
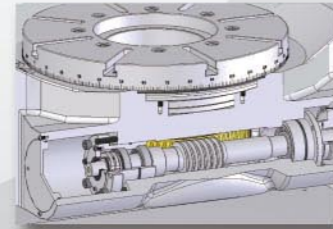
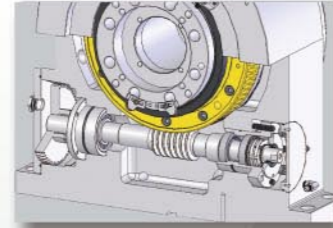

Each Pinnacle machine is subject to dynamic and static accuracy tests. Pinnacle machine accuracy meets ISO 10791 VDI 3441, ISO 230, JIS B6388 and ASMEB5 standards.

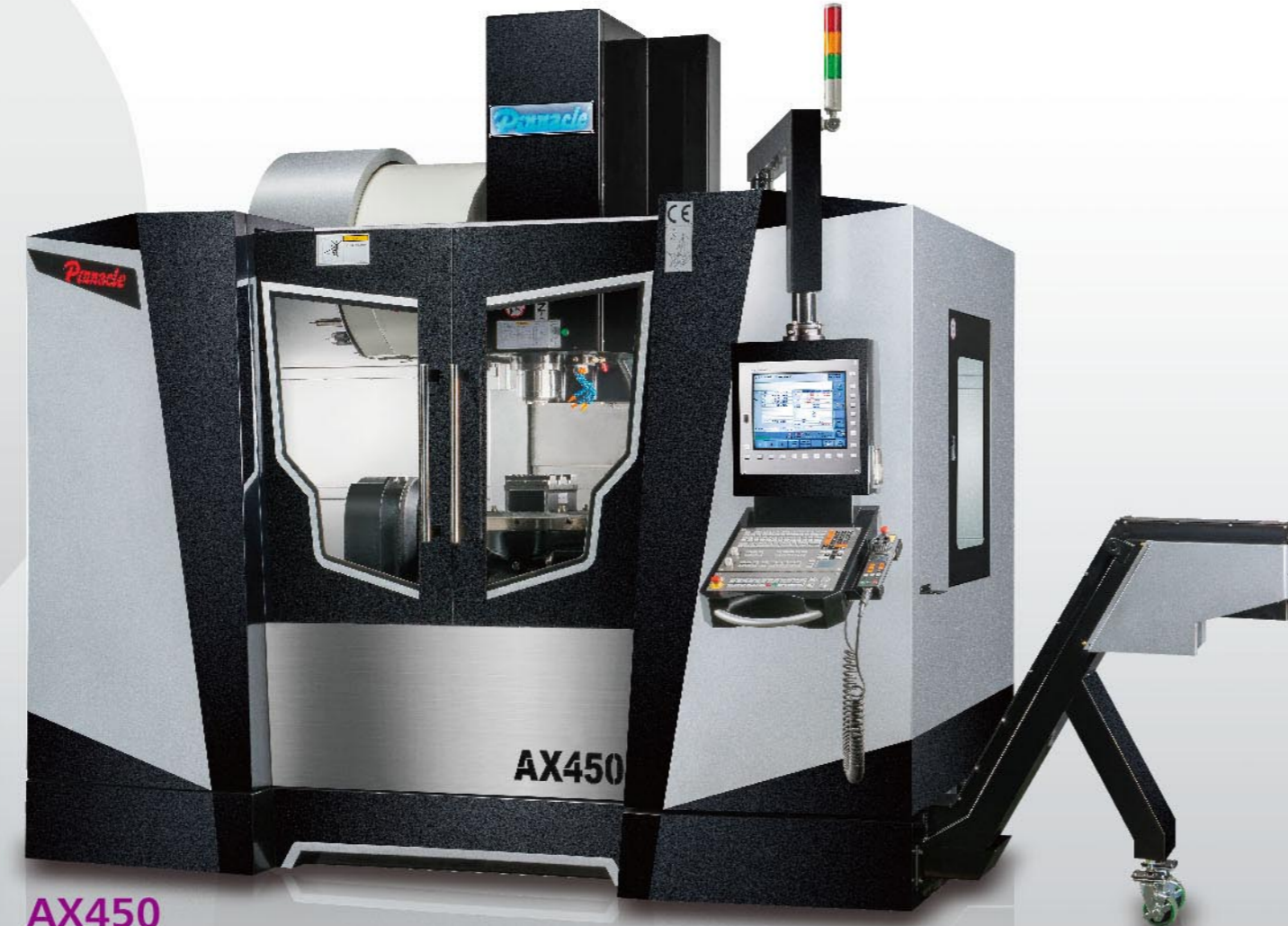

AX450

- 760 x 610 x 560 mm Travel
- A Axis Tilt 220° (±110°)
- C Axis Rotary 360°
- Rapid Feedrate 30/30/24 m/min
- 9/12 Kw Spindle Motor
- ISO40 Spindle Taper
- X, Y & Z Axis Linear Roller Guideway

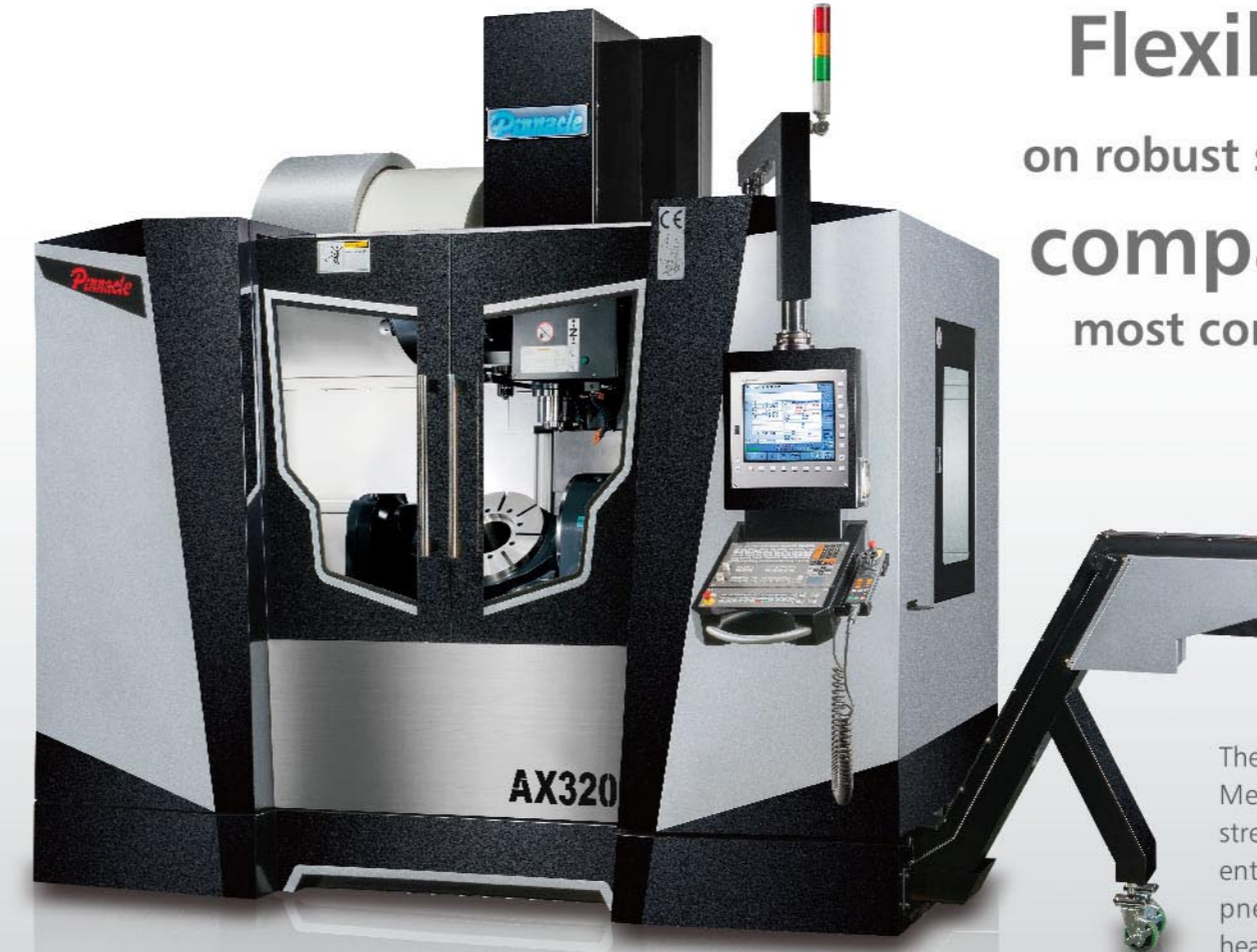

AX320

- 660 x 610 x 610 mm Travel
- A Axis Tilt 150° (-120°+30°)
- C Axis Rotary 360°
- Rapid Feedrate 30/30/24 m/min
- 9/12 Kw Spindle Motor
- ISO40 Spindle Taper
- X, Y & Z Axis Linear Roller Guideway

Flexible application on robust structure **Simple** and **compact** design to solve your most complicated machining jobs.

High-Tech Expertise in 5-axis Machining

5-AXIS MACHINING CENTER

The main components are made from high quality Meehanite cast iron, which are annealed and stress-relieved before machining. The spindle with entire headstock assembly is counter-balanced by pneumatic system to minimize the column and headstock vibration during acceleration / deceleration. The 5-axis synchronized machining allows complicated work pieces to be finished in just one setup, and it increases machining efficiency and accuracy, also reduces machine idle time. Pinnacle AX 320 / AX 450 are your best choice for producing aerospace components, medical equipment and any parts with multiple curved faces.

The **A/C-axis** on models **AX170/AX500** are directly driven by motor, featuring no backlash and high speed. These features make the machine excellent for 5-axis simultaneous machining.

AX170

- Rotary table diameter Ø170 mm.
- Table rotation and tilting are directly driven by motor.
- A/C-axis rotating speeds 60/200 rpm.
- A/C-axis positioning accuracy (sec.): 5"/5".
- A/C-axis repeatability accuracy (sec.): 4"/4".
- X,Y,Z-axis travel 320 x 320 x 380 mm.
- A-axis tilting degree 240°(-120°/+120°)
- C-axis swiveling degree 360°.
- X,Y,Z-axis rapid traverse rates 36/36/36 m/min.
- Spindle motor: 3.7/9.5 kw.
- Spindle taper: ISO 40.
- Linear ways on X,Y,Z-axis.



- Rotary Table diameter Ø500.
- Table rotation and tilting are DD motor.
- Positioning accuracy, A/C-axis: 8"/8".
- Repeatability accuracy, A/C-axis: 4"/4".

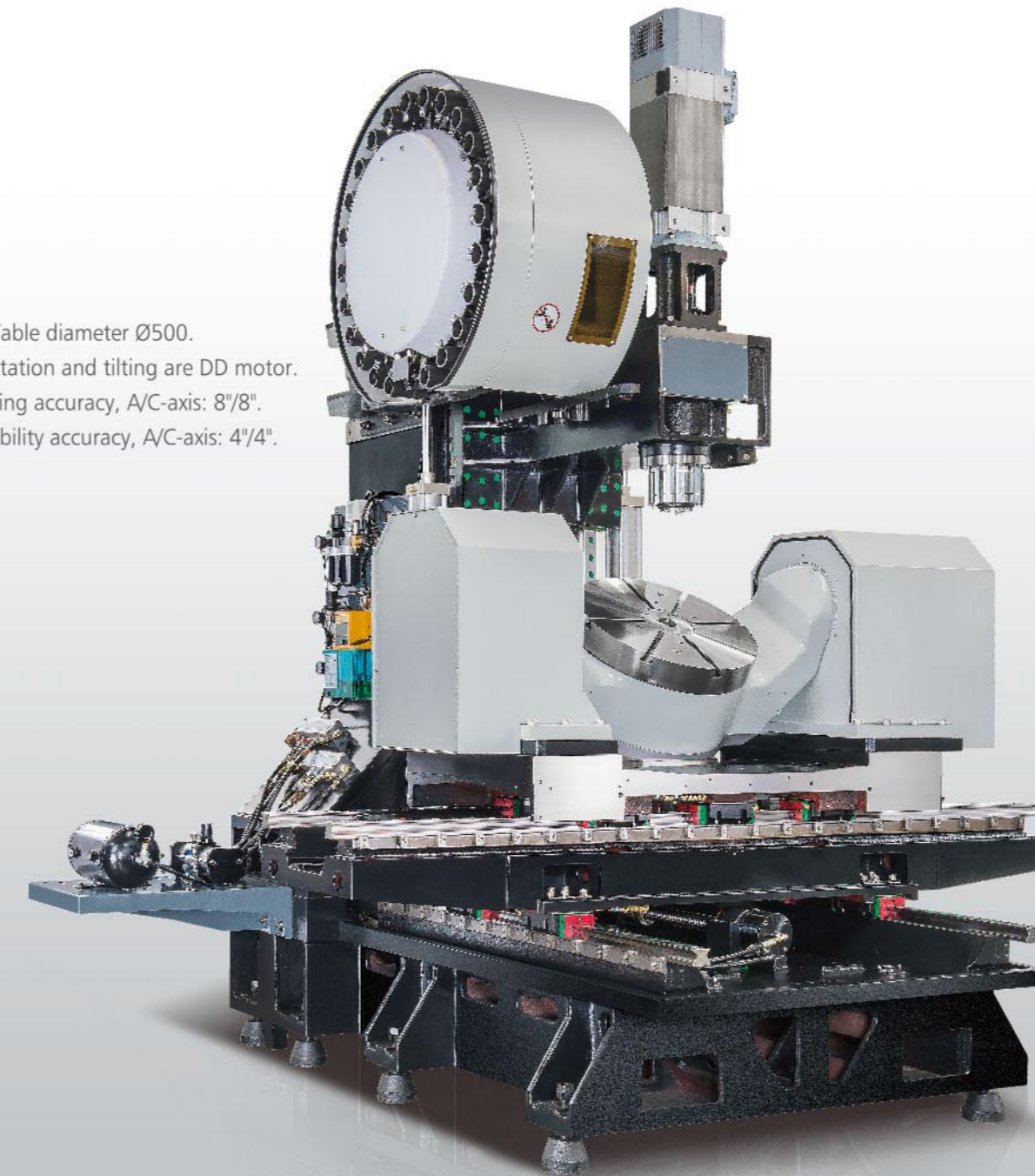

3 + 2 = ∞

Infinite Solutions

Rigid • Stable • Accurate

3 linear axes X/Y/Z plus rotary and tilting axes A/C offers almost infinite solutions to your 5-axis or multiple faces machining jobs. The two-in-one rotary/tilting table features easy maintenance and low service cost. AX320 A-axis swivels 150° and AX450 & AX500 swivels 220° to optimize machining space and allows complex workpieces to be finished in just one setup and reducing cycle time.

AX500

- 760 x 610 x 560 mm Travel.
- Table Size: Ø500 mm.
- A Axis Tilt 220°(±110°)---DD motor.
- C Axis Rotary 360°----DD motor.
- Rapid Feedrate 30/30/24 m/min.
- 9/12 Kw Spindle Motor.
- ISO40 Spindle Taper.
- X, Y & Z Axis Linear Roller Guide way.

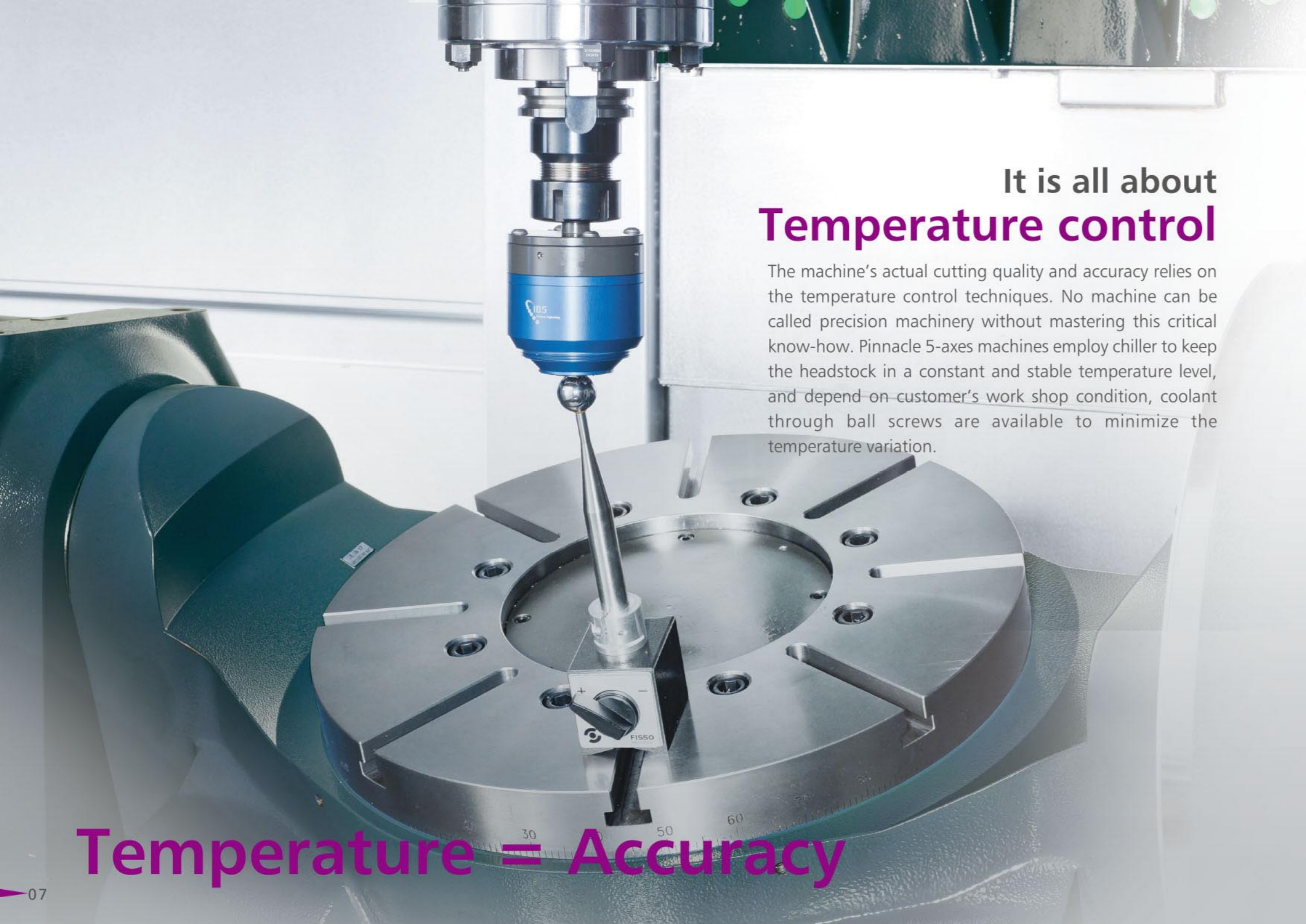

It is all about Temperature control

The machine's actual cutting quality and accuracy relies on the temperature control techniques. No machine can be called precision machinery without mastering this critical know-how. Pinnacle 5-axes machines employ chiller to keep the headstock in a constant and stable temperature level, and depend on customer's work shop condition, coolant through ball screws are available to minimize the temperature variation.

Temperature = Accuracy

Outstanding craftsmanship

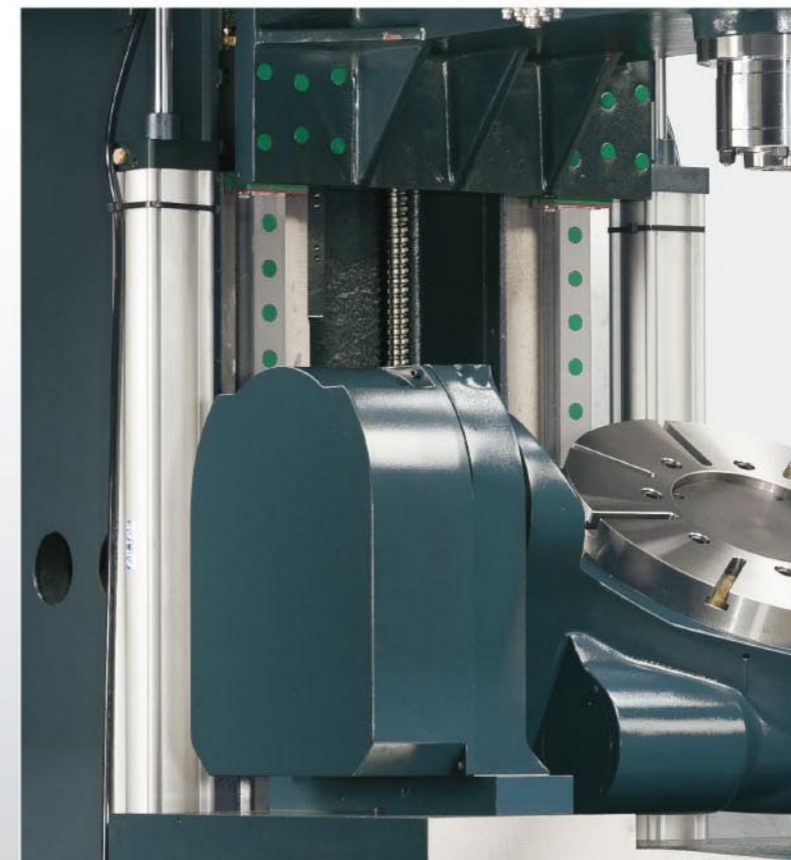

Pneumatic Balance System

The Z-axis is pneumatic counter-balanced via high response pneumatic cylinders. Plus an air reservoir tank to boost the balancing performance, ensuring fast and stable Z-axis movement, giving high surface finish.

Cooling System to Spindle

The spindle oil cooler permits the spindle to keep a constant temperature running and ensures long service life. It also provides high efficiency machining and high accuracy.

Hollow Ball Screw with Cooling System

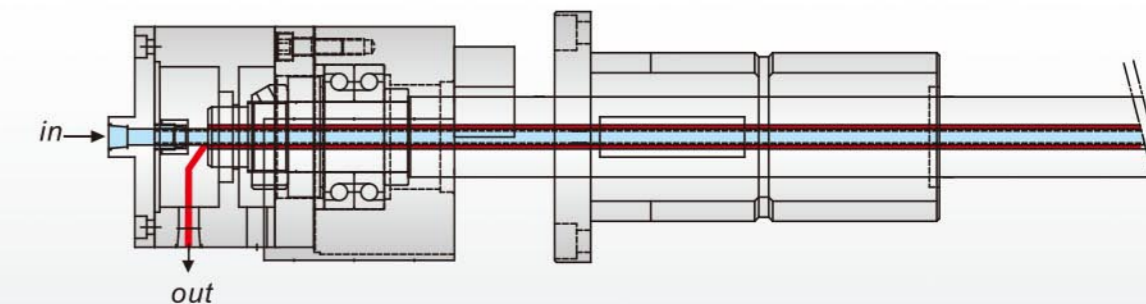

Oil cooling through ball screws on X, Y, Z axis minimizes thermal deformation and backlash, while ensuring smooth motion during rapid traverse.



Linear Roller Guideway

X/Y/Z axes adopt roller guideways for optimum rigidity and speed. 6 rolling shoes on X/Z axes minimize damping effect.



Rigid Machine Base and Saddle

Drive motors direct coupled with pretensioned and oversized ballscrews to ensure cutting quality.

WORKING CAPACITY



AX170/200

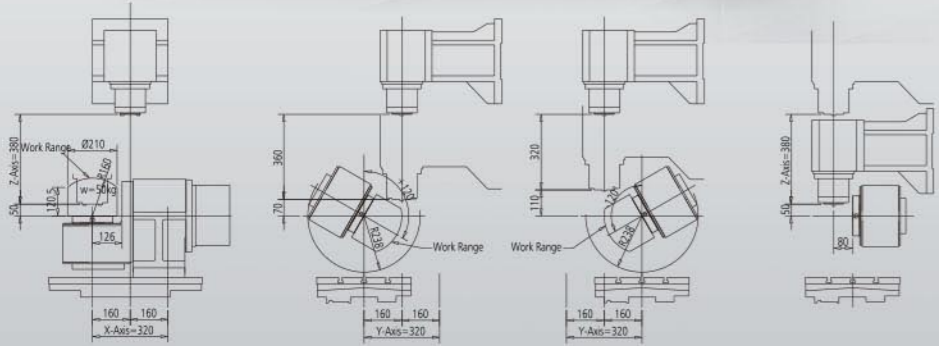

AX320

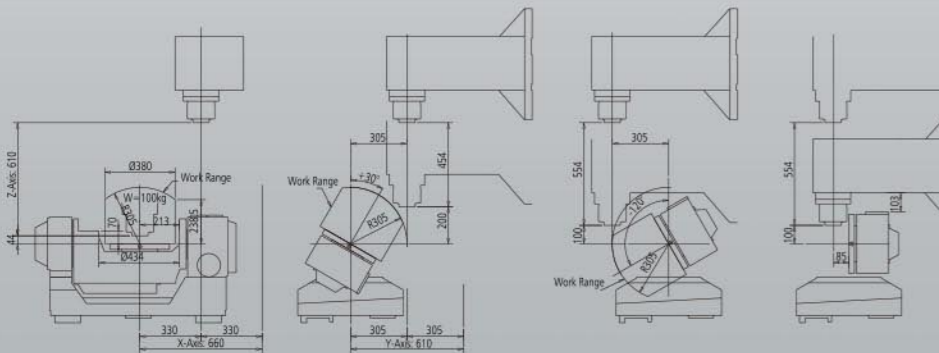

AX350

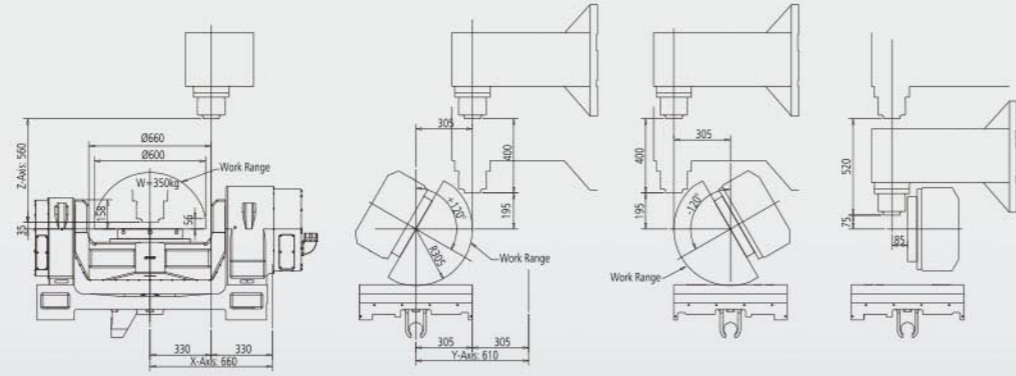

AX450

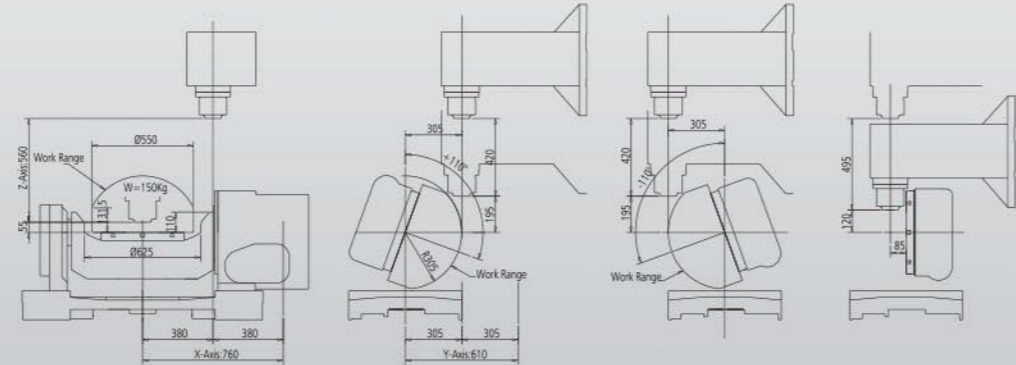

AX500

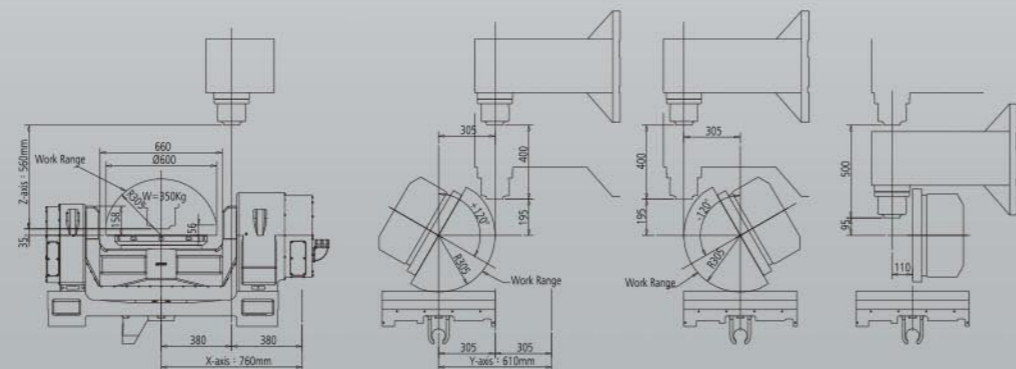

Quality is not a job, it is our attitude.



ISO certification



CE certification



All Aspect Quality System

Quality comes not from inspection but from every Pinnacle staffs' mentality. The state-of-the-art inspection equipments only help us to prove our attitude and accuracy results.



CNC CONTROLLER SYSTEM
 AX series is high speed, high accuracy with HEIDENHAIN TNC640 5-axis simultaneously controlled machining center. Equips 10000(12000/15000) rpm direct drive spindle, or optional 18000/20000 rpm built-in spindle.

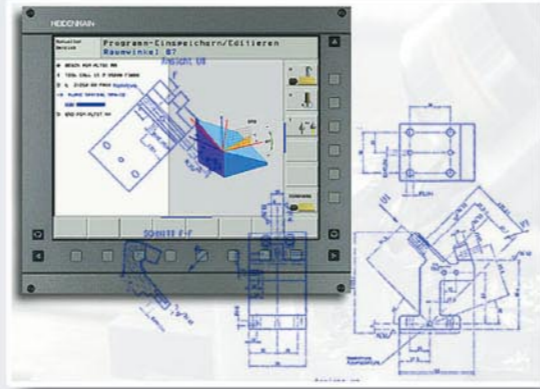

PLANE Function
 The PLANE feature makes it easy to define a tilted working plane.

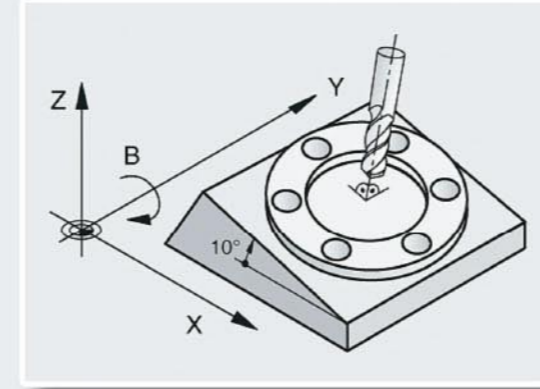

Tilting the Working Plane
 With Cycle 19 with swivel heads or tilting tables, you program the operation as usual in the working plane, for example in X/Y. The machine runs the program in a plane that has been tilted by one or more rotary axes with respect to the main plane.

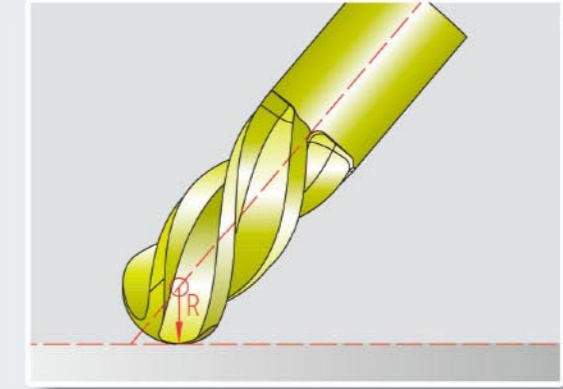

TCPM function (Tool Center Point Management)
 In five-axis operations, TCPM function to move the tool reliably on the contour and ensure that the work surface is not damaged. Maintain the position of the tool tip when positioning with tilted axes. With the aid of the TCPM function, the TNC640 automatically corrects the tool path for the machine geometry and the tool length as well as compensates the tool radius in three dimensions.



Chip Flushing System
 Chip flushing system is equipped to remove cutting chips inside of enclosure, which prevents chip accumulation and any possible damage to the linear guideways and ball screws.

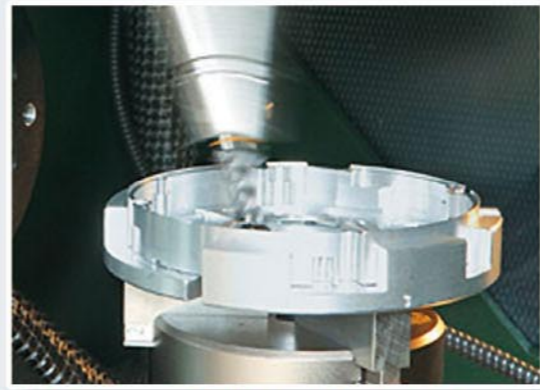

DCM (Dynamic Collision Monitoring)
 DCM enables you to check for collisions in the test run mode before actually machining a part. To avoiding machine down times. Simulation for a safety process.

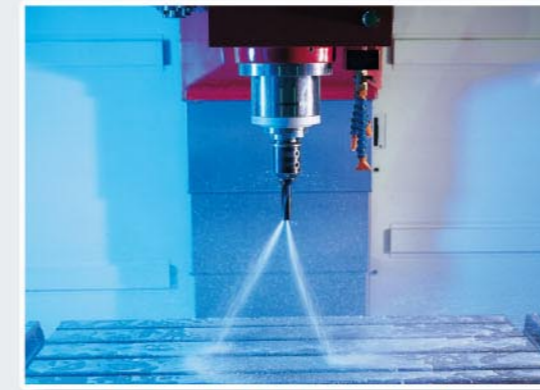

Coolant Through Spindle (Option)
 20 Bar high pressure pump and sub tank assure CTS system offers the highest efficiency of chip disposal.



Chip Conveyor (Option)
 Hinge type or scraper type chip conveyor in front side of machine (able head to left or right) removes chips from machine.

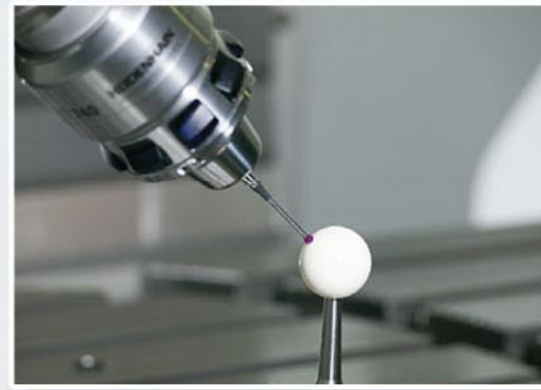

Kinematics Opt. (Option)
 Kinematics Opt is an important component to help you meet these high requirements: With a HEIDENHAIN touch probe inserted, a 3-D touch probe cycle measures your machine's rotary axes fully automatically. The results of measurement are the same, regardless of whether the axis is a rotary table, a tilting table or a swivel head.

FLOOR SPACE:

TABLE SIZE: AX170

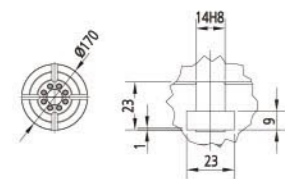

TABLE SIZE: AX320

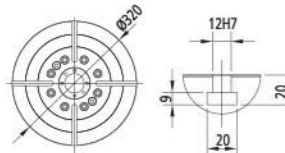

TABLE SIZE: AX350

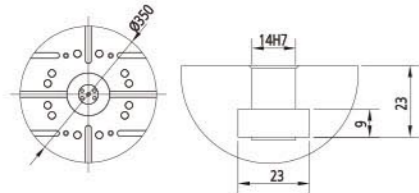

TABLE SIZE: AX450

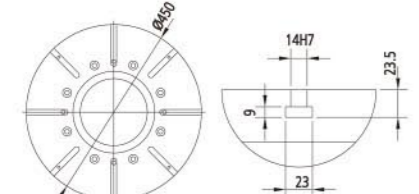
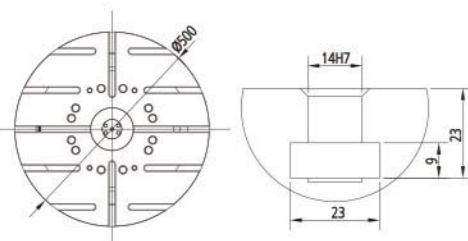
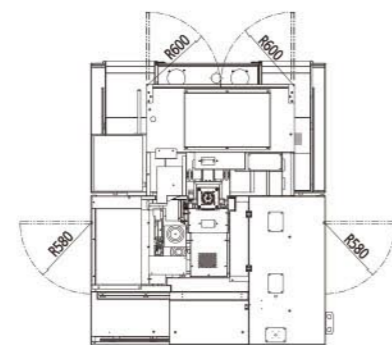

TABLE SIZE: AX500



FLOOR SPACE: AX170



FLOOR SPACE: AX320

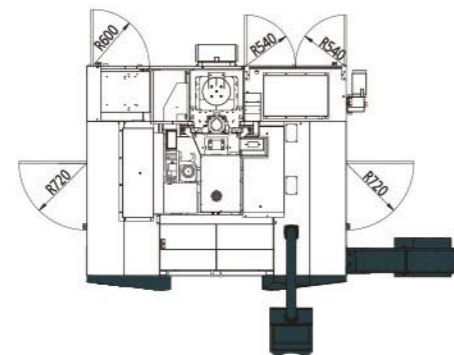

FLOOR SPACE: AX450 / AX500 (350)

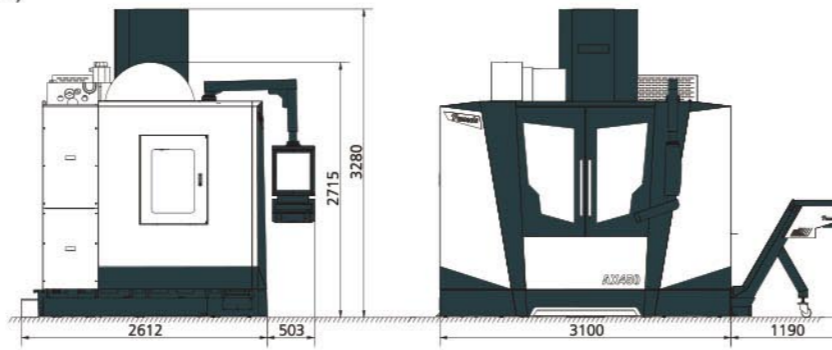
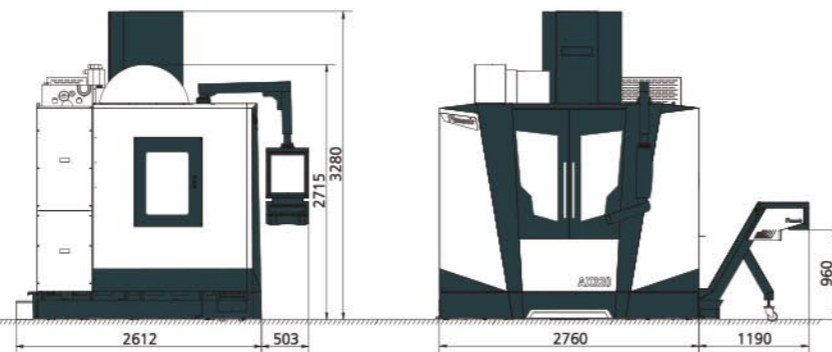
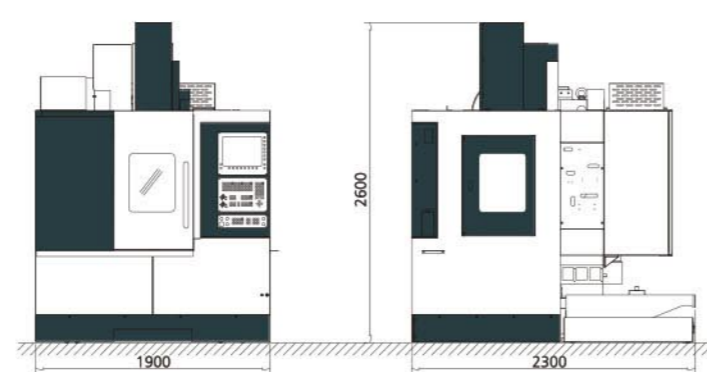
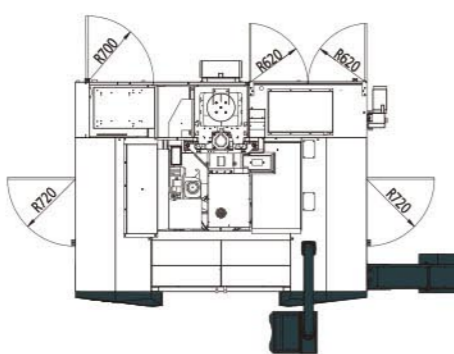

SPECIFICATIONS:

MODEL	AX170(200)	AX320	AX450	AX500(350)
TABLE				
TABLE SIZE & NUMBER (mm)	Ø170 (200)	Ø320	Ø450	Ø500(350)
TRAVEL RANGES (X/Y/Z mm)	320 x 320 x 380	660 x 610 x 610	760 x 610 x 560	760(660) x 610 x 560
SCREW SIZE	14 x 90° x 4	12 x 90° x 4	14 x 100 x 8	14 x 100 x 12(8)
MAX. TABLE LOAD (Kg)	50	100	150	350
MAX. WORKPIECE SIZE (WxH mm)	Ø210 x 160	Ø380 x 305	Ø550 x 305	Ø600 x 305
DIAMETER OF TABLE HOLE (mm)	Ø40	Ø50	Ø171	Ø50
SPINDLE NOSE TO TABLE SURFACE (mm)	50~430	44~654	55~615	35~595
A Axis, Tilt (deg)/(0.001°)	240°(± 120°)	150° (-120° / +30°)	220°(± 110°)	220°(± 110°)
C Axis, Rotary (deg)/(0.001°)	360°	360°	360°	360°
SPINDLE				
DISTANCE BETWEEN COLUMN (mm)	ISO40	ISO40	ISO40	ISO40
SPINDLE INNER DIAMETER (mm)	Ø60	Ø70	Ø70	Ø70
SPINDLE SPEED (rpm) Belt	-	10000	10000	10000
SPINDLE SPEED (rpm) Direct drive	12000 (15000)	10000 (12000/15000)	10000 (12000/15000)	10000 (12000/15000)
SPINDLE SPEED (rpm) Built-in	-	20000	20000	20000
MAIN MOTOR (con/30min kW)	3.7/9.5	9/12	9/12	9/12
AXIS SERVO MOTOR				
RAPID FEED RATE (X/Y/Z m/min)	36 / 36 / 36	30 / 30 / 24	30 / 30 / 24	30 / 30 / 24
FEED RATE (X/Y/Z m/min)	20	10	10	10
FEED RATE (A/C rev/min)	60 / 200	25 / 25	5.5 / 11.1	60 / 90
X-Axis Rated Torque (Nm)	1.5	10	10	10
Y-Axis Rated Torque(Nm)	1.5	10	10	10
Z-Axis Rated Torque(Nm)	2.1	10	10	10
A-Axis Rated Torque(Nm)	205	5	10	860
C-Axis Rated Torque(Nm)	35	3.8	10	430
AUTO TOOL CHANGER				
ATC TYPE	DISK	DISK (CHAIN)	DISK (CHAIN)	DISK (CHAIN)
CAM TYPE	ARM	ARM	ARM	ARM
TOOL SELECTION (Bi-direction)	RANDOM	RANDOM	RANDOM	RANDOM
TOOL STORAGE CAPACITY (PCs)	20	24 / 30(40)	24 / 30(40)	24 / 30(40)
MAX. TOOL DIAMETER (mm)	Ø75	Ø90 / Ø76(Ø76)	Ø90 / Ø76(Ø76)	Ø90 / Ø76(Ø76)
MAX. TOOL LENGTH	250	250	250	250
MAX. TOOL WEIGHT	8	8	8	8
MISCELLANEOUS				
AIR REQUIREMENT (Kg/cm ²)	6	6	6	6
VOLTAGE	380	220	220	380
POWER REQUIREMENT (KVA)	40	40	40	40
COOLANT TANK CAPACITY (L)	150	250	300	300
MACHINE WEIGHT (KGs)	2800	6500	7000	7100
MACHINE HEIGHT (mm)	2600	3280	3280	3280
FLOOR SPACE (LxW mm)	1900 x 2300	2760 x 2390	3100 x 2390	3100 x 2390
PACKING SIZE (LxWxH mm)	2100 x 2500 x 2560	2810 x 2230 x 2560	3150 x 2230 x 2560	3150 x 2230 x 2560

● ALL SPECIFICATIONS AND DESIGNS ARE SUBJECT TO CHANGE WITHOUT NOTICE.

Standard Accessories:

- Air Blast Through Spindle
- Air Blast for Workpiece (nose)
- Coolant Flushing System
- 3 Axes Telescopic Covers
- Full Splash Guard
- Automatic Lubrication System
- Working Lamp
- Operation Status Light
- Arm Type 24-tool ATC
- Z Axis Pneumatic Balance System
- Cooling System
- Air Gun/Water Gun
- MPG Handwheel
- Heat Exchanger
- RS-232 Interface
- Rigid Tapping
- Spindle Oil Cooler
- Hollow Ball Screws with Cooling System
- A-axis Rotary Encoder
- C-axis Rotary Encoder
- Adjusting Tools and Box
- Leveling Bolts and Pads
- Operation and Programming Manual
- Chain Type Chip Conveyor

Options:

- Transformer
- Coolant Through Spindle
- 3 Axes Linear Scales
- Auto Tool Length Measurement
- Auto Workpiece Measurement
- FANUC Controller
- MITSUBISHI Controller
- SIEMENS Controller