

STANDARD Rock Picker

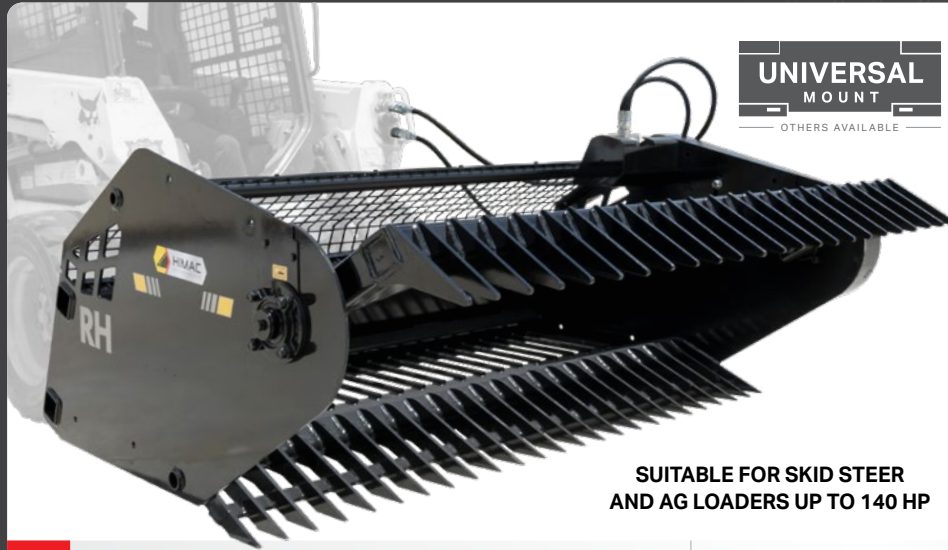

**UNIVERSAL
MOUNT**
OTHERS AVAILABLE

**SUITABLE FOR SKID STEER
AND AG LOADERS UP TO 140 HP**



FEATURES

- » Single bidirectional rotation reel arm
- » Generous tyne spacings for clean rock removal
- » High torque motor and pressure relief valve
- » Includes mount, hoses and couplings

OPTIMAL ROCK SIZE
100 - 500 mm

REQUIRED FLOW
40 - 80 LPM

CODE	DESCRIPTION	TYNE SPACING	WORK WIDTH	LOAD CAPACITY	VOLUME	WEIGHT	PRICING
RP16UN	1810 mm Rock Picker	70 mm	1600 mm	Up to 1000 kg	0.60 m ³	470 kg	GET QUOTE
RP20UN	2210 mm Rock Picker		2000 mm		0.75 m ³	560 kg	

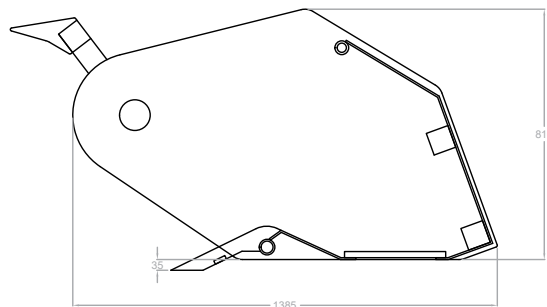

RP16UN / RP20UN
STANDARD Skid Steer / Euro Model